

WISENT

CATALOGUE

ROCK SOLID & STRONG

SAWING MACHINES

COLUMN DRILLING MACHINES

MAGNETIC DRILLING MACHINES

GRINDING MACHINES

DEBURRING MACHINES

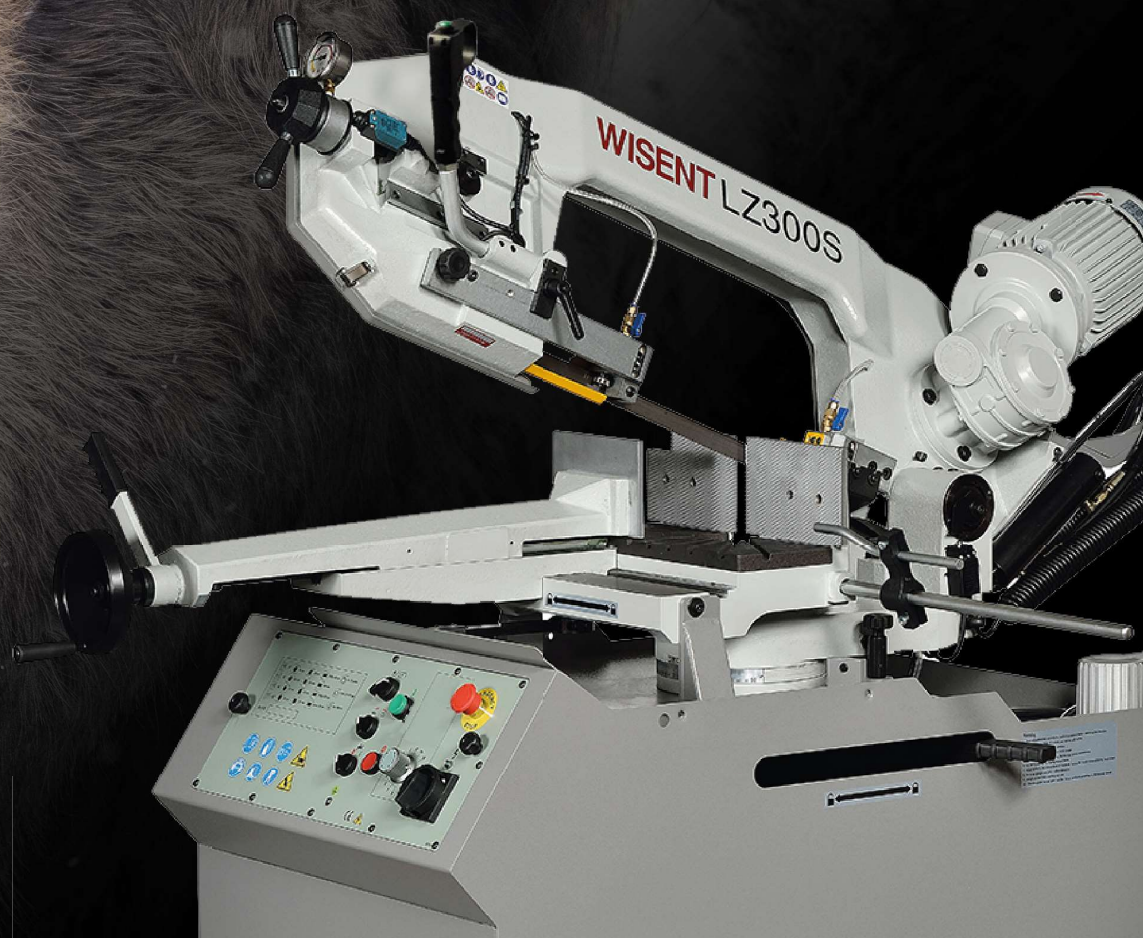

METALWORKING MACHINES



ROCK SOLID & STRONG

The Wisent is the largest living mammal in the European landscape. Despite its substantial weight, you can recognize the Wisent by its slender build, short horns and brown fur.

These Wisent move effortlessly and quickly between trees and on plains. Wisents can grow 2 meters tall and 3 meters long at a weight of up to 850 kg.

The Wisent is also known as a survivor in winter and summer and is an all-rounder in light and harsh conditions.

A beautiful name for the carefully selected robust metalworking machines.

Rock solid and strong under all circumstances.

TABLE OF CONTENTS

SAWING MACHINES

Transportable band sawing machines	5
Stationary band sawing machines	10
Roller conveyors and length stops	20
Oil dispensing system and band saw blades	21
Transportable circular sawing machines	23
Stationary circular sawing machines	24

DRILLING MACHINES

Magnetic base drilling machines	32
Cutters	33
Tabletop drilling / tapping machines	36
Column drilling / tapping machines	42

PIPEWORKING MACHINES

Belt grinding machines	55
Deburring machines	60
Pipe grinding machines	62
Pipe notchers	64

BENDING TOOLS

Stationary hydraulic bend press table	65
Pipe benders	66

WISENT

LZ300RH

BAND SAW MACHINES

Wisent band saw machines

Transportable band saw machines

The Wisent transportable band saws are ideally suited for fine sawing work. The sawing machines are compact and lightweight and therefore easy to take on a job. This series of sawing machines are "dry" sawing machines, so sawing without coolant or oil. All portable band saws are supplied with saw blade and material stop.



Wisent TLZ 100V



Wisent TLZ 125V



Wisent TLZ 175V



Wisent TLZ 200V

Transportable band saw machines

Type	TLZ 100V	TLZ 125V	TLZ 175V	TLZ 200V
Voltage	1 Phase / 230 Volt	1 Phase / 230 Volt	1 Phase / 230 Volt	1 Phase / 230 Volt
Motor power	0.85 kW	1 kW	1.5 kW	1.65 kW
Cutting speed	Variable 30 ~ 80 m/min	Variable 30 ~ 80 m/min	Variable 30 ~ 80 m/min	Variable 30 ~ 80 m/min
Vice opening	105 mm	135 mm	150 mm	170 mm
Coolant system	No	No	No	No
Mitre adjustment L+R	0 – 45°	0 – 60°	0 – 60°	0 – 60°
Saw blade dimensions	1,330 x 13 x 0.65 mm	1,440 x 13 x 0.65 mm	1,735 x 13 x 0.65 mm	2,030 x 20 x 0.90 mm
Weight approx.	18 kg	20 kg	30 kg	35 kg
Article number	667100027	667100226	667100028	667100229
Capacity				
90° ∅	100 mm	125 mm	150 mm	170 mm
90° □	100 x 100 mm	125 x 125 mm	140 x 140 mm	166 x 166 mm
45° ∅	65 mm	85 mm	100 mm	130 mm
45° □	65 x 65 mm	85 x 85 mm	100 x 100 mm	130 x 130 mm
60° ∅		50 mm	70 mm	75 mm
60° □		50 x 50 mm	65 x 65 mm	75 x 75 mm

Wisent TLZ 100V

Transportable band saw machine

- Compact and lightweight
- DC motor 1 Phase 230 Volt, 0.85 kW
- Electronic adjustable speed 30 ~ 80 m/min
- Electronic feedback
- Manual saw feed
- Dry cutting
- Vice clamp opening 105 mm
- Mitre adjustment 0-45° right
- Mechanical saw blade tension control
- Ball bearing saw guide
- Bi-metal saw blade 1,330 x 13 x 0.65 mm
- 24 Volt safety switch
- Weight approx. 18 kg

Machine comes complete with:

- Bi-metal M42 saw blade
- Material stop



Capacity				
∟	∅	□	▭	kW
90°	100 mm	100 mm	100 x 100 mm	0.85
45° R	65 mm	65 mm	65 x 65 mm	0.85

Technical specifications	
Voltage	1 Phase / 230 Volt
Motor power	0.85 kW
Cutting speed	Variable 30 ~ 80 m/min
Vice opening	105 mm
Coolant system	No
Mitre cutting R	0 – 45°
Saw blade dimensions	1,330 x 13 x 0.65 mm
Weight approx.	18 kg
Article number	667100027

Accessories				
Excellent quality band saw blades for perfect cutting results.				
<ul style="list-style-type: none"> • Flexible • Long tool life • Good chip removal • Low noise and vibration 				
Length mm	TPI			
	6/10	8/12	10/14	14/18
1,330 x 13 x 0.65	•	•	•	•

Wisent TLZ 125V

Transportable band saw machine

- Compact and lightweight
- DC motor 1 Phase 230 Volt, 1 kW
- Electronically adjustable speed 30 ~ 80 m/min
- Electronic feedback
- Manual saw feed
- Dry cutting
- Vice clamp opening 135 mm
- Mitre adjustment 0-60° right
- Mechanical saw blade tension control
- Ball bearing saw guide
- Bi-metal saw blade 1,440 x 13 x 0.65 mm
- 24 Volt safety switch
- Weight approx. 20 kg

Machine comes complete with:

- Bi-metal M42 saw blade
- Material stop



Capacity				
∠	∅	□	▭	kW
90°	125 mm	125 mm	125 x 125 mm	1.0
45° R	80 mm	85 mm	85 x 85 mm	1.0
60° R	50 mm	50 mm	50 x 50 mm	1.0

Technical specifications	
Voltage	1 Phase / 230 Volt
Motor power	1 kW
Cutting speed	Variable 30 ~ 80 m/min
Vice opening	135 mm
Coolant system	No
Mitre cutting R	0 – 60°
Saw blade dimensions	1,440 x 13 x 0.65 mm
Weight approx.	20 kg
Article number	667100226

Accessories				
Excellent quality band saw blades for perfect cutting results.				
<ul style="list-style-type: none"> • Flexible • Long tool life • Good chip removal • Low noise and vibration 				
Length mm	6/10	8/12	10/14	14/18
1,440 x 13 x 0.65	•	•	•	•

Wisent TLZ 175V

Transportable band saw machine

- Compact and lightweight
- DC motor 1 Phase 230 Volt, 1.5 kW
- Electronically adjustable speed 30 ~ 80 m/min
- Electronic feedback
- Manual saw feed
- Dry cutting
- Vice clamp opening 150 mm
- Mitre adjustment 0 - 60° right
- Mechanical saw blade tension control
- Ball bearing saw guide
- Bi-metal saw blade 1,735 x 13 x 0.65 mm
- 24 Volt safety switch
- Weight approx. 20 kg

Machine comes complete with:

- Bi-metal M42 saw blade
- Material stop



Capacity				
∟	∅	□	▭	kW
90°	150 mm	140 mm	140 x 140 mm	1.5
45° R	100 mm	100 mm	100 x 100 mm	1.5
60° R	70 mm	65 mm	65 x 65 mm	1.5

Technical specifications	
Voltage	1 Phase / 230 Volt
Motor power	1.5 kW
Cutting speed	2 speeds 30 ~ 80 m/min
Vice opening	150 mm
Coolant system	No
Mitre cutting R	0 - 60°
Saw blade dimensions	1,735 x 13 x 0.65 mm
Weight approx.	30 kg
Article number	667100028

Accessories				
Excellent quality band saw blades for perfect cutting results.				
<ul style="list-style-type: none"> • Flexible • Long tool life • Good chip removal • Low noise and vibration 				
Length mm	6/10	8/12	10/14	14/18
1,735 x 13 x 0.65	•	•	•	•

Wisent TLZ 200V

Transportable band saw machine

- Compact and lightweight
- DC motor 1 Phase 230 Volt, 1.65 kW
- Electronically adjustable speed 30 ~ 80 m/min
- Electronic feedback
- Manual saw feed
- Dry cutting
- Vice opening 175 mm
- Mitre adjustment 0 - 60° right
- Mechanical saw blade tension control
- Ball bearing saw guide
- Bi-metal saw blade 2,030 x 20 x 0.9 mm
- 24 Volt safety switch
- Weight approx. 35 kg

Machine comes complete with:

- Bi-metal M42 saw blade
- Material stop



Capacity				
∟	∅	□	▭	kW
90°	170 mm	170 mm	170 x 170 mm	1.65
45° R	130 mm	130 mm	130 x 150 mm	1.65
60° R	75 mm	75 mm	75 x 75 mm	1.65

Technical specifications	
Voltage	1 Phase / 230 Volt
Motor power	1.65 kW
Cutting speed	Variable 30 ~ 80 m/min
Vice opening	175 mm
Coolant system	No
Mitre cutting R	0 - 60°
Saw blade dimensions	2,030 x 20 x 0.90 mm
Weight approx.	35 kg
Article number	667100229

Accessories				
Excellent quality band saw blades for perfect cutting results.				
<ul style="list-style-type: none"> • Flexible • Long tool life • Good chip removal • Low noise and vibration 				
Length mm	6/10	8/12	10/14	14/18
2,030 x 13 x 0.90	•	•	•	•

Wisent band saw machines

Manual, Semi-automatic and Semi-automatic hydraulic band saw machines

Stationary manual and gravity down feed band sawing machines

Manual saw bow lifting, mechanical blade tension with hand wheel, precision blade-guide with tungsten carbide pads and with bearings, manually adjustable prism vice with quick lock lever, complete with base and integrated coolant system.

Semi-automatic (hydraulic closed system):

Manual operating vice, automatic saw feed and manual saw bow lifting.

Semi-automatic hydraulic (hydraulic controlled)

Automatic closing of vice, automatic saw feed, automatic saw bow lifting and automatic opening of vice.



Wisent LZ 150V
Semi-automatic



Wisent LZ 215
Manual



Wisent LZ 280S
Semi-automatic



Wisent LZ 300S
Semi-automatic



Wisent LZ 300RHA
Semi-automatic hydraulic



Wisent LZ 350HA
Semi-automatic hydraulic



Wisent LZ 460HA
Semi-automatic hydraulic



Wisent LZ 530HA
Semi-automatic hydraulic



Wisent VS 500
Manual

Wisent LZ 150V

Semi-automatic band saw machine

- Sturdy base with cooling lubrication unit
- 1 Phase motor, 230 Volt, 1.1 kW
- Variable cutting speed 20 ~ 65 m/min.
- Mitre cutting 0 - 60° right
- Continuously adjustable saw feed
- Manual saw bow lifting
- Mechanical blade tensioning
- Bi-metal saw blade 1,735 x 13 x 0.65 mm
- Ball bearing saw guide
- Rectangular saw table
- Quick clamp vice, vice opening 170 mm
- Saw bed height ca. 900 mm
- Integrated coolant system
- Clearly laid out operating panel with zero voltage safety switch and emergency stop
- Weight ca. 100 kg

Machine comes complete with:

- Bi-metal M42 saw blade
- Base cabinet
- Coolant system
- Material stop





All Wisent sawing machines can be fitted with MPS roller conveyors and MPS measuring systems

Capacity				
∠	∅	□	▭	kW
90°	145 mm	140 mm	170 x 140 mm	1.1
45° R	125 mm	115 mm	125 x 115 mm	1.1
60° R	70 mm	70 mm	90 x 70 mm	1.1

Technical specifications	
Voltage	1 Phase / 230 Volt
Motor power	1.1 kW
Cutting speed	Variable 20 ~ 65 m/min
Vice opening	170 mm
Coolant system	Standard
Mitre cutting R	0 – 60°
Saw blade dimensions	1,735 x 13 x 0.65 mm
Weight approx.	100 kg
Article number	667100029

Options

MPS roller conveyors

- 2000 series, closed model
- Width 350 mm, roller pitch 250 mm
- Height 900 mm ± 50 mm
- Color RAL7001 and RAL7011

MPS measuring systems

Manual or automatic movable length stop systems. Available from 2 meters. Suitable for mounting on MPS roller conveyors..

Wisent LZ 215

Manual band saw machine

- Sturdy base with cooling lubrication unit
- 3 Phase motor, 400 Volt, 0.6-0.85 kW
- 2 cutting speeds 40 / 80 m/min.
- Mitre cutting 0 - 45° right
- Manual saw feed
- Mechanical blade tensioning
- Bi-metal saw blade 2,060 x 20 x 0.9 mm
- Hard metal ball bearing saw guide
- Rectangular saw table
- Quick clamp vice, vice opening 215 mm
- Changeable wear plate on moving clamp
- Saw bed height ca. 900 mm
- Integrated coolant system, large capacity coolant pump
- Clearly laid out operating panel with zero voltage safety switch and emergency stop
- Weight ca. 220 kg

Machine comes complete with:

- Bi-metal M42 saw blade
- Base cabinet
- Coolant system
- Material stop





All Wisent sawing machines can be fitted with MPS roller conveyors and MPS measuring systems

Capacity				
∠	∅	□	▭	kW
90°	150 mm	120 mm	200 x 120 mm	0.6 / 0.85
45° R	120 mm	90 mm	130 x 90 mm	0.6 / 0.85

Technical specifications	
Voltage	3 Phase / 400 Volt
Motor power	0.6 / 0.85 kW
Cutting speed	2 speeds 40 / 80 m/min
Vice opening	215 mm
Coolant system	Standard
Mitre cutting R	0 - 45°
Saw blade dimensions	2,060 x 20 x 0.9 mm
Weight ca.	220 kg
Article number	667100023

Options

MPS roller conveyors

- 2000 series, closed model
- Width 350 mm, roller pitch 250 mm
- Height 900 mm ± 50 mm
- Color RAL7001 and RAL7011

MPS measuring systems

Manual or automatic movable length stop systems. Available from 2 meters. Suitable for mounting on MPS roller conveyors.

Wisent LZ 280S

Semi-automatic band saw machine

- Sturdy base with cooling lubrication unit
- 3 Phase motor, 400 Volt, 0.75-1.1 kW
- 2 cutting speeds 32 / 66 m/min.
- Mitre cutting 0 - 60° right
- Continuously adjustable saw feed
- Manual saw bow lifting
- Mechanical blade tensioning
- Bi-metal saw blade 2,450 x 27 x 0.9 mm
- Tungsten carbide ball bearing saw guide
- Rectangular saw table
- Quick clamp vice, vice opening 250 mm
- Changeable wear plate on moving clamp
- Saw bed height ca. 925 mm
- Integrated coolant system, large capacity coolant pump
- Clearly laid out operating panel with zero voltage safety switch and emergency stop
- Weight ca. 280 kg

Machine comes complete with:

- Bi-metal M42 saw blade
- Base cabinet
- Coolant system
- Material stop





All Wisent sawing machines can be fitted with MPS roller conveyors and MPS measuring systems

Capacity				
∟	∅	□	▭	kW
90°	220 mm	215 mm	250 x 155 mm	0.75 / 1.1
45° R	160 mm	150 mm	160 x 110 mm	0.75 / 1.1
60° R	100 mm	85 mm	80 x 95 mm	0.75 / 1.1

Technical specifications	
Voltage	3 Phase / 400 Volt
Motor power	0.75 / 1.1 kW
Cutting speed	2 speeds 32 / 66 m/min
Vice opening	250 mm
Coolant system	Standard
Mitre cutting R	0 – 60°
Saw blade dimensions	2,450 x 27 x 0.9 mm
Weight ca.	280 kg
Article number	667100022

Options

MPS roller conveyors

- 2000 series, closed model
- Width 350 mm, roller pitch 250 mm
- Height 900 mm ± 50 mm
- Color RAL7001 and RAL7011

MPS measuring systems

Manual or automatic movable length stop systems. Available from 2 meters. Suitable for mounting on MPS roller conveyors.

Wisent LZ 300S

Semi-automatic band saw machine

- Sturdy steel machine base out of one piece
- 3 Phase motor, 400 Volt, 1.1-1.5 kW
- 2 cutting speeds 35 / 70 m/min.
- Quick Approach system
- Sawing start mounted in operating lever
- Mitre cutting 0 - 60° right and 0 - 45° left
- Continuously adjustable saw feed
- Manual saw bow lifting
- Adjustable and readable hydraulic blade tension control
- Bi-metal saw blade 2,750 x 27 x 0.9 mm
- Tungsten carbide ball bearing saw guide
- Saw blade cleaner
- Sturdy rectangular saw table with changeable parts
- Fast moveable quick clamp vice, vice opening 310 mm
- Changeable wear plates on clamping jaws
- Saw bed height ca. 950 mm
- Integrated coolant system, large capacity coolant pump
- Clearly laid out operating panel with zero voltage safety switch and emergency stop
- Weight ca. 390 kg

Machine comes complete with:

- Bi-metal M42 saw blade
- Base cabinet
- Coolant system
- Material stop



All Wisent sawing machines can be fitted with MPS roller conveyors and MPS measuring systems

Capacity				
∟	∅	□	▭	kW
90°	255 mm	210 mm	310 x 210 mm	1.1 / 1.5
45° L	170 mm	170 mm	200 x 170 mm	1.1 / 1.5
45° R	220 mm	210 mm	220 x 200 mm	1.1 / 1.5
60° R	135 mm	135 mm	135 x 135 mm	1.1 / 1.5

Technical specifications	
Voltage	3 Phase / 400 Volt
Motor power	1.1 / 1.5 kW
Cutting speed	2 speeds 35 / 70 m/min
Vice opening	310 mm
Coolant system	Standard
Mitre cutting L+R	45° - 0° - 60°
Saw blade dimensions	2,750 x 27 x 0.9 mm
Weight ca.	390 kg
Article number	667100300

Options



MPS roller conveyors

- 2000 series, closed model
- Width 350 mm, roller pitch 250 mm
- Height 900 mm ± 50 mm
- Color RAL7001 and RAL7011



MPS measuring systems

Manual or automatic movable length stop systems. Available from 2 meters. Suitable for mounting on MPS roller conveyors.

Wisent LZ 300RHA

Semi-automatic hydraulic band saw machine

- Sturdy steel machine base out of one piece
- Fully hydraulically driven
- 3 Phase motor, 400 Volt, 1.1-1.5 kW
- 2 cutting speeds 35 / 70 m/min.
- Quick Approach system
- Sawing start mounted in operating lever
- Mitre cutting 0 - 60° right and 0 - 45° left
- Continuously adjustable hydraulic saw feed
- Automatic saw bow lifting
- Adjustable and readable hydraulic blade tension control
- Bi-metal saw blade 2,750 x 27 x 0.9 mm
- Tungsten carbide ball bearing saw guide
- Saw blade cleaner
- Flat rotating round saw table
- Fast moveable quick clamp vice, vice opening 310 mm
- Changeable wear plates on clamping jaws
- Saw bed height ca. 1.050 mm
- Integrated coolant system, large capacity coolant pump
- Clearly laid out operating panel with zero voltage safety switch and emergency stop
- Weight ca. 510 kg



Machine comes complete with:

- Bi-metal M42 saw blade
- Base cabinet
- Coolant system
- Material stop

All Wisent sawing machines can be fitted with MPS roller conveyors and MPS measuring systems

Capacity				
∟	∅	□	▭	kW
90°	255 mm	255 mm	310 x 160 mm	1.1 / 1.5
45° L	185 mm	180 mm	170 x 230 mm	1.1 / 1.5
45° R	180 mm	170 mm	140 x 220 mm	1.1 / 1.5
60° R	115 mm	115 mm	115 x 160 mm	1.1 / 1.5

Technical specifications

Voltage	3 Phase / 400 Volt
Motor power	1.1 / 1.5 kW
Cutting speed	2 speeds 35 / 70 m/min
Vice opening	310 mm
Coolant system	Standard
Mitre cutting L+R	45° - 0° - 60°
Saw blade dimensions	2,750 x 27 x 0.9 mm
Weight ca.	510 kg
Article number	667100312

Options



MPS roller conveyors

- 2000 series, closed model
- Width 350 mm, roller pitch 250 mm
- Height 900 mm ± 50 mm
- Color RAL7001 and RAL7011



MPS measuring systems

Manual or automatic movable length stop systems. Available from 2 meters. Suitable for mounting on MPS roller conveyors.

Wisent LZ 350HA

Semi-automatic hydraulic band saw machine

- Sturdy steel machine base out of one piece
- Fully hydraulically driven
- 3 Phase motor, 400 Volt, 1.5-1.9 kW
- 2 cutting speeds 35 / 70 m/min.
- Quick Approach system
- Sawing start mounted in operating lever
- Mitre cutting 0 - 60° right and 0 - 45° left
- Continuously adjustable hydraulic saw feed
- Automatic saw bow lifting
- Adjustable and readable hydraulic blade tension control
- Bi-metal saw blade 2,925 x 27 x 0.9 mm
- Tungsten carbide ball bearing saw guide
- Saw blade cleaner
- Sturdy rectangular saw table with changeable parts
- Fast moveable quick clamp vice, vice opening 360 mm
- Changeable wear plates on clamping jaws
- Saw bed height ca. 990 mm
- Integrated coolant system, large capacity coolant pump
- Clearly laid out operating panel with zero voltage safety switch and emergency stop
- Weight ca. 675 kg

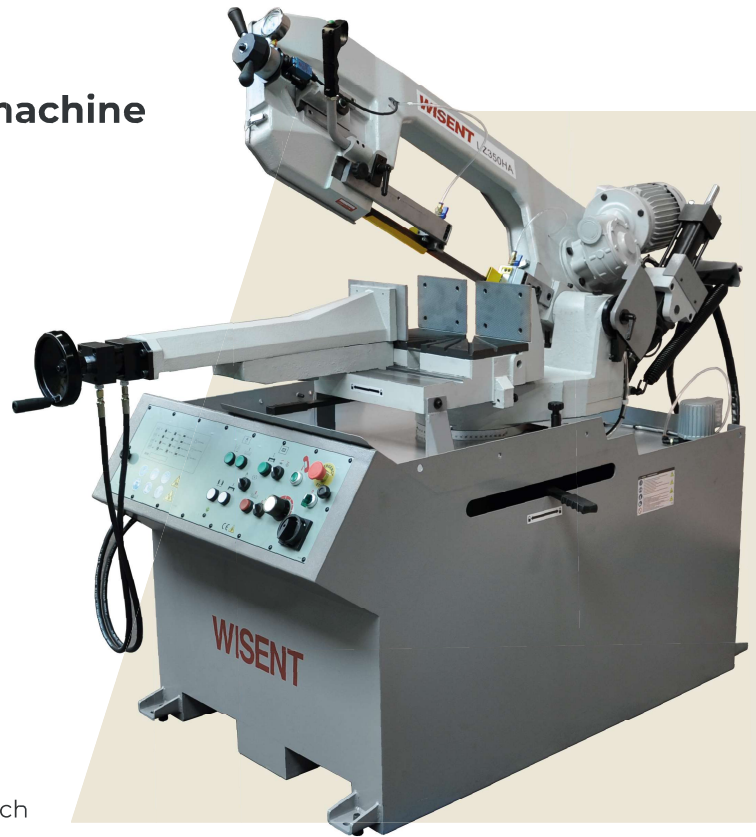

Machine comes complete with:

- Bi-metal M42 saw blade
- Base cabinet
- Coolant system
- Material stop

All Wisent sawing machines can be fitted with MPS roller conveyors and MPS measuring systems

Capacity				
∟	∅	□	▭	kW
90°	275 mm	270 mm	330 x 230 mm	1.5 / 1.9
45° L	220 mm	180 mm	220 x 140 mm	1.5 / 1.9
45° R	230 mm	220 mm	220 x 210 mm	1.5 / 1.9
60° R	145 mm	140 mm	140 x 180 mm	1.5 / 1.9

Technical specifications

Voltage	3 Phase / 400 Volt
Motor power	1.5 / 1.9 kW
Cutting speed	2 speeds 35 / 70 m/min
Vice opening	360 mm
Coolant system	Standard
Mitre cutting L+R	45° - 0° - 60°
Saw blade dimensions	2,925 x 27 x 0.9 mm
Weight ca.	675 kg
Article number	667100327

Options



MPS roller conveyors

- 2000 series, closed model
- Width 350 mm, roller pitch 250 mm
- Height 900 mm ± 50 mm
- Color RAL7001 and RAL7011



MPS measuring systems

Manual or automatic movable length stop systems. Available from 2 meters. Suitable for mounting on MPS roller conveyors.

Wisent LZ 460HA

Semi-automatic hydraulic band saw machine

- Sturdy steel machine base out of one piece
- Fully hydraulically driven
- 3 Phase motor, 400 Volt, 1.5-2.2 kW
- 2 cutting speeds 40 / 80 m/min.
- Quick Approach system
- Sawing start on control panel
- Mitre cutting 0 - 60° right and 0 - 45° left
- Continuously adjustable hydraulic saw feed
- Automatic saw bow lifting
- Adjustable and readable hydraulic blade tension control
- Bi-metal saw blade 3,960 x 27 x 0.9 mm
- Tungsten carbide ball bearing saw guide
- Powered chip brush
- Sturdy rectangular saw table with changeable part
- Fast moveable quick clamp vice, vice opening 460 mm
- Changeable wear plates on clamping jaws
- Saw bed height ca. 860 mm
- Integrated coolant system, large capacity coolant pump
- Clearly laid out operating panel with zero voltage safety switch and emergency stop
- Weight ca. 830 kg



Machine comes complete with:

- Bi-metal M42 saw blade
- Base cabinet
- Coolant system
- Material stop

All Wisent sawing machines can be fitted with MPS roller conveyors and MPS measuring systems

Capacity				
∠	∅	□	▭	kW
90°	330 mm	330 mm	460 x 250 mm	1.5 / 2.2
45° L	305 mm	280 mm	305 x 250 mm	1.5 / 2.2
45° R	305 mm	280 mm	305 x 250 mm	1.5 / 2.2
60° R	205 mm	180 mm	205 x 250 mm	1.5 / 2.2

Technical specifications

Voltage	3 Phase / 400 Volt
Motor power	1.5 / 2.2 kW
Cutting speed	2 speeds 40 / 80 m/min
Vice opening	460 mm
Coolant system	Standard
Mitre cutting L+R	45 - 0 - 60°
Saw blade dimensions	3,960 x 27 x 0.9 mm
Weight ca.	830 kg
Article number	667100026

Options



MPS roller conveyors

- 2000 series, closed model
- Width 350 mm, roller pitch 250 mm
- Height 900 mm ± 50 mm
- Color RAL7001 and RAL7011



MPS measuring systems

Manual or automatic movable length stop systems. Available from 2 meters. Suitable for mounting on MPS roller conveyors.

Wisent LZ 530HA

Semi-automatic hydraulic band saw machine

- Sturdy steel machine base out of one piece
- Fully hydraulically driven
- 3 Phase motor, 400 Volt, 2.2 kW
- Variable speed (inverter) 20 ~ 80 m/min.
- Quick Approach system
- Sawing start mounted in operating lever
- Mitre cutting 0 - 60° right and 0 - 45° left
- Continuously adjustable hydraulic saw feed
- Automatic saw bow lifting
- Adjustable and readable hydraulic blade tension control
- Bi-metal saw blade 3,770 x 34 x 1.1 mm
- Tungsten carbide ball bearing saw guide
- Saw blade cleaner
- Sturdy rectangular saw table with changeable parts
- Fast moveable quick clamp vice, vice opening 530 mm
- Changeable wear plates on clamping jaws
- Saw bed height ca. 960 mm
- Integrated coolant system, large capacity coolant pump
- Clearly laid out operating panel with zero voltage safety switch and emergency stop
- Weight ca. 700 kg



Machine comes complete with:



- Bi-metal M42 saw blade
- Solid base cabinet
- Coolant system
- Material stop

All Wisent sawing machines can be fitted with MPS roller conveyors and MPS measuring systems

Capacity				
∠	∅	□	▭	kW
90°	355 mm	300 mm	490 x 300 mm	2.2
45° L	290 mm	250 mm	250 x 250 mm	2.2
45° R	350 mm	290 mm	340 x 290 mm	2.2
60° R	230 mm	180 mm	220 x 180 mm	2.2

Technical specifications	
Voltage	3 Phase / 400 Volt
Motor power	2.2 kW
Cutting speed	Variable 20 ~ 80 m/min
Vice opening	530 mm
Coolant system	Standard
Mitre cutting L+R	45° - 0° - 60°
Saw blade dimensions	3,770 x 34 x 1.1 mm
Weight ca.	700 kg
Article number	667100334

Options

MPS roller conveyors

- 2000 series, closed model
- Width 350 mm, roller pitch 250 mm
- Height 900 mm ± 50 mm
- Color RAL7001 and RAL7011

MPS measuring systems

Manual or automatic movable length stop systems. Available from 2 meters. Suitable for mounting on MPS roller conveyors.

Wisent VS 500

Vertical band saw machine

- Vertical band sawing machine
- For cutting of plate, bended and set material in steel, stainless steel, aluminum, wood and plastics
- 3 Phase motor, 400 Volt, 1.5kW
- Protection covers with micro switches
- Variable adjustable speed with digital reading 0 ~ 230 m/min
- Tilttable work table L 15° - 0° - 30° R
- Dimensions work table 660 x 700 mm
- Longitudinal and mitre guide
- Cleaning brush
- Dimension saw blade 3,960 x 13 x 0.65 mm
- Mechanical saw blade tension
- Welding unit with cutting and grinding device
- Integrated coolant system
- Work lamp 24 Volt
- Working height 980 mm
- Weight ca. 470 kg

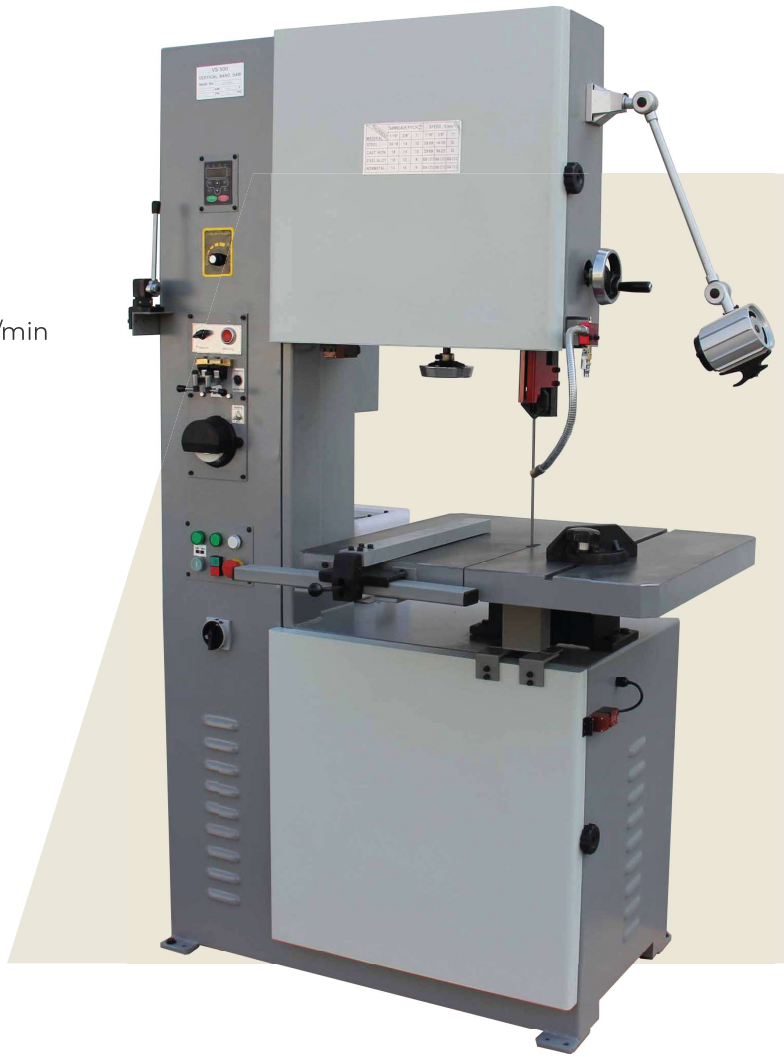

Capacity

Cutting height max.	310 mm
Cutting width max.	500 mm

Technical specifications

Voltage	3 Phase / 400 Volt
Motor power	0.75 / 1.1 kW
Cutting speed	Variable 75 ~ 1500 m/min
Vice opening	-
Coolant system	Standard
Tilttable work table	15 – 0 – 30°
Saw blade dimensions	3,960 x 13 x 0.65 mm
Weight ca.	470 kg
Article number	667100030

Wisent LZ 350HA Setup

Including MPS roller conveyors and measuring system

Set existing of:

- 1 MPS infeed roller conveyor 2000-2
- 2 WISENT band saw machine LZ350HA
- 3 MPS 60° machine linked table
- 4 MPS digital length measuring system MPS75
- 5 MPS outfeed roller conveyor 2000-2

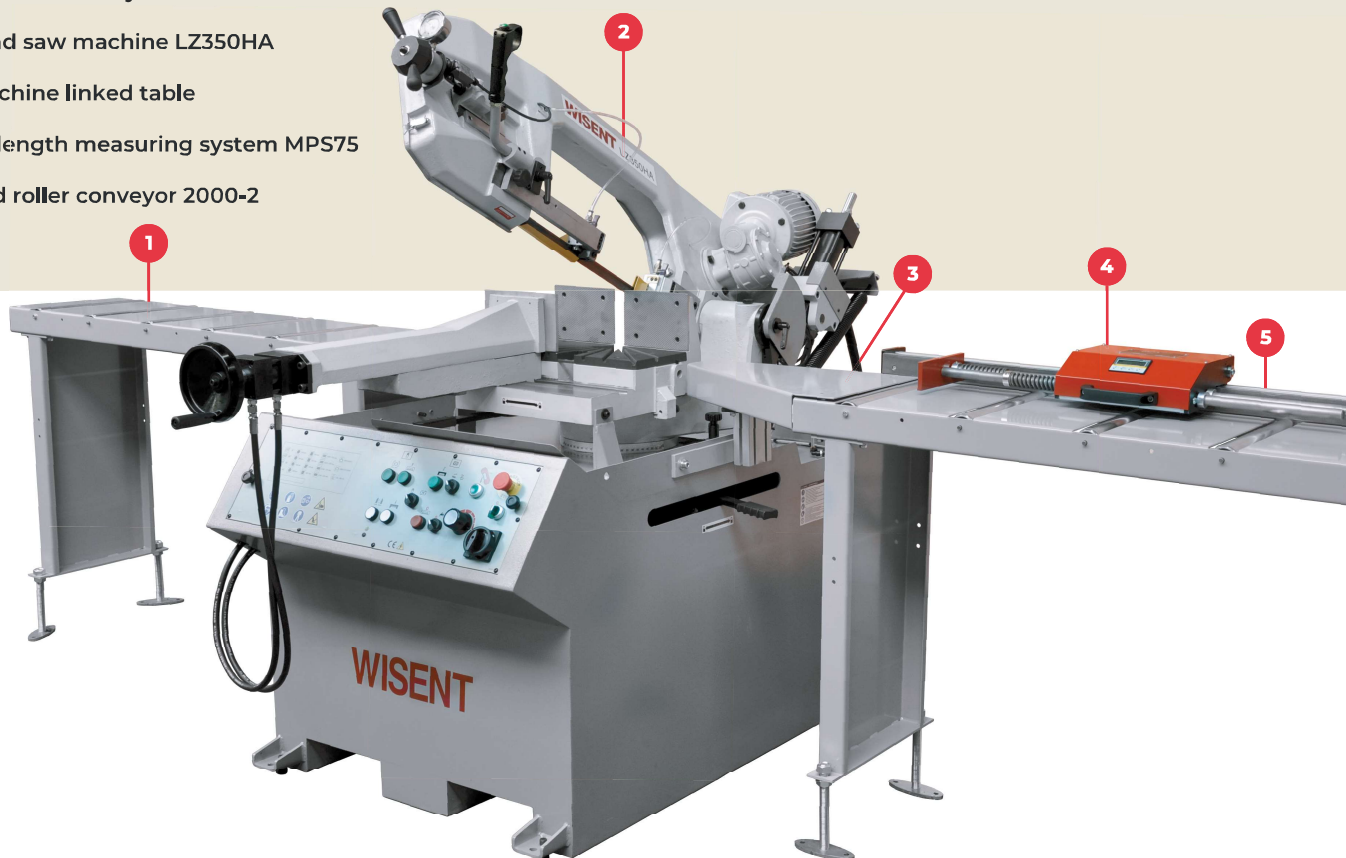

MPS roller conveyors 2000 series, closed model

- Available from 2 meters
- Equipped with plastic, steel or steel galvanized rollers
- Roll width 350 mm, roll pitch 250 mm
- Color RAL7001 or RAL7011



MPS70 and MPS75 series manual measuring systems

- Available from 2 meters
- Foldable stop and spring-buffered
- Rear guide in Trespa or plain steel
- Can be mounted left or right of the machine

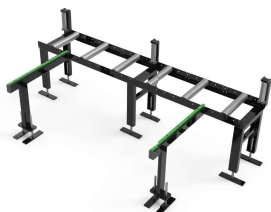

MPS roller 5090 series, closed model

- Available from 2 meters
- Equipped with steel rollers
- Roll width 500 mm, roll pitch 500 mm
- Color RAL7021



MPS Powerstop series of automatic measuring systems

- Available from 2 meters
- Folding stop and spring buffered
- Rear guide in Trespa or plain steel
- Can be mounted both left and right of the machine

Wisent MSD121

Lubrication system for circular saws, band saws, column drills and other machining machines

The lubrication system ensures the correct dosage of lubricating oil on the saw blade, drill or other type of tool. Minimal use of lubricating oil makes the system environmentally friendly and ensures “dry” machining. The lubrication system is economical in use, especially when sawing or drilling pipes and profiles.

Most used is the type MSD121. open model, equipped with 2 dosing pumps and a 1 liter reservoir.

Complete with:

- 2 pieces double 3.5 meter air hoses (oil and air).
- Orion compressed air connection.
- Magnetic coil 24 Volt / DC (or your choice).
- Fork nozzle for band saw machine.

Options and accessories:

- MPS greasing oil, can 5 liter
- Machinemounting
- Closed model in a cabinet (MSD131)
- Special nozzles
- Ball shut off valves
- Metal coated air hose
- Selector switch microdosing system
- Coolant pump
- Level sensor

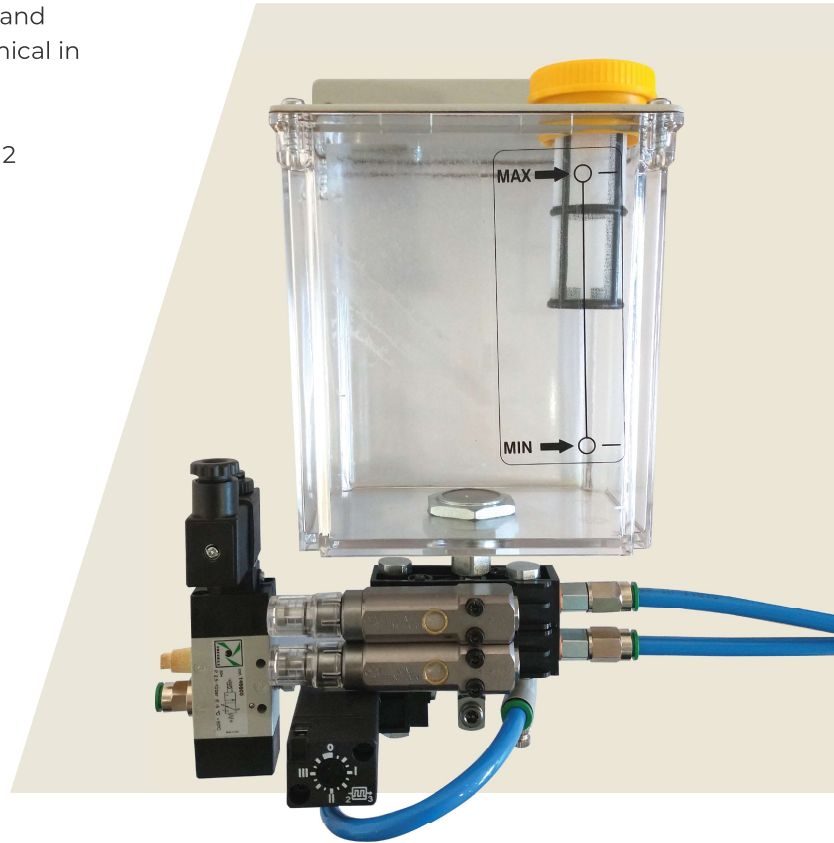

Wisent band saw blades

Wisent band saw blades

	Length mm		TPI						
	2/3	3/4	4/6	5/8	6/10	8/12	10/14	14/18	
1,330 x 13 x 0.65					•	•	•	•	
1,440 x 13 x 0.65					•	•	•	•	
1,735 x 13 x 0.65					•	•	•	•	
2,030 x 20 x 0.9					•	•	•	•	
2,060 x 20 x 0.9			•	•	•	•	•		
2,450 x 27 x 0.9			•	•	•	•	•		
2,750 x 27 x 0.9		•	•	•	•	•	•		
2,925 x 27 x 0.9		•	•	•	•	•			
3,960 x 27 x 0.9		•	•	•	•	•			
3,770 x 34 x 1.1	•	•	•	•					

WISENT MODEL M
355MM METAL CUTTING SA

CIRCULAR SAW MACHINES

Wisent MC355

Transportable universal circular saw machine

- Compact circular saw for job sites
- Suitable for cutting ferrous and non ferrous materials
- Dry cutting without coolant or oil
- 1 Phase motor, 230 Volt, 2.2 kW
- High speed range 1.300 RPM
- Mitre cutting 0 - 45° right
- Manual saw feed
- Including TCT saw blade 72T
- Diameter saw blade Ø355 mm, shaft hole 25.4 mm
- Quick vice, vice opening 130 mm
- Weight ca. 26 kg

Machine comes complete with:

- TCT saw blade 72T



Capacity				
∟	∅	□	▭	kW
90°	130 mm	120 mm	140 x 100 mm	2.2
45°	95 mm	80 mm	90 x 80 mm	2.2

Technical specifications	
Voltage	1 Phase / 230 Volt
Motor power	2.2 kW
Cutting speed	1.300 RPM
Vice opening	130 mm
Coolant system	No
Mitre cutting L+R	0 – 45°
Saw blade dimensions ∅	355 x 25.4 mm
Weight ca.	26 kg
Article number	253200001

Accessories		
Wisent TCT HM circular saw blades		
Dimensions mm	TPI	Article number
Saw blade Ø 355 x 25.4 mm	72T	853300012
Saw blade Ø 355 x 25.4 mm	80T	853300013
Saw blade Ø 355 x 25.4 mm	90T	853300016

Wisent CZM315L DV

Stationary hinged metal circular saw machine

- Base cabinet with integrated coolant system
- 3 Phase motor, 400 Volt, 0.8-1.3 kW
- 2 cutting speeds 18 / 36 rpm
- Hardened and grounded gears
- Oil bath lubrication
- Mitre cutting left + right 45° - 0 - 45° and 90° transverse cuts
- Manual saw feed
- HSS circular saw blade Ø315 mm, shaft hole 32 mm
- Automatic opening safety cover
- Double centering vice
- Changeable wear plates on clamping jaws
- Saw bed height ca. 955 mm
- Integrated coolant system, large capacity coolant pump
- Central control panel with zero voltage safety switch and emergency stop
- Weight ca. 230 kg

Machine comes complete with:

- HSS circular saw blade Ø315 mm, shaft hole 32 mm
- Base cabinet
- Coolant system
- Double centering vice



Wisent saw blades CZM315L DV

Dimensions mm	TPI	Article number
Saw blade Ø 315 x 2.5 x 32 mm	120T	127100220
Saw blade Ø 315 x 2.5 x 32 mm	160T	127100214
Saw blade Ø 315 x 2.5 x 32 mm	180T	127100211
Saw blade Ø 315 x 2.5 x 32 mm	200T	127100208
Saw blade Ø 315 x 2.5 x 32 mm	220T	127100205

Capacity

∠	∅	□	▭	kW
90°	100 mm	100 mm	90 x 140 mm	0.8 / 1.3
45°	90 mm	90 mm	90 x 100 mm	0.8 / 1.3

Technical specifications

Voltage	3 Phase / 400 Volt
Motor power	0.8 / 1.3 kW
Cutting speed	18 / 36 RPM
Coolant system	Yes
Mitre cutting L+R	45° - 0° - 45° - 90°
Saw blade dimensions ∅	315 x 2.5 x 32 mm
Weight ca.	230 kg
Article number	667100088

Options



MPS roller conveyors

- 2000 series, closed model
- Width 350 mm, roller pitch 250 mm
- Height 900 mm ± 50 mm
- Color RAL7001 and RAL7011



MPS measuring systems

Manual or automatic movable length stop systems. Available from 2 meters. Suitable for mounting on MPS roller conveyors.

Wisent CZM350L DV

Stationary hinged metal circular saw machine

- Base cabinet with integrated coolant system
- 3 Phase motor, 400 Volt, 1.1-2.2 kW
- 2 cutting speeds 18 / 36 rpm
- Hardened and grounded gears
- Oil bath lubrication
- Mitre cutting left + right 45° - 0 - 45° and 90° transverse cuts
- Manual saw feed
- HSS circular saw blade Ø350 mm, shaft hole 32 mm
- Automatic opening safety cover
- Double centering vice
- Changeable wear plates on clamping jaws
- Saw bed height ca. 955 mm
- Integrated coolant system, large capacity coolant pump
- Central control panel with zero voltage safety switch and emergency stop
- Weight ca. 245 kg

Machine comes complete with:

- HSS circular saw blade Ø350 mm, shaft hole 32 mm
- Base cabinet
- Coolant system
- Double centering vice



Wisent saw blades CZM350L DV

Dimensions mm	TPI	Article number
Saw blade Ø 350 x 2.5 x 32 mm	120T	127100292
Saw blade Ø 350 x 2.5 x 32 mm	160T	127100286
Saw blade Ø 350 x 2.5 x 32 mm	180T	127100283
Saw blade Ø 350 x 2.5 x 32 mm	200T	127100280
Saw blade Ø 350 x 2.5 x 32 mm	220T	127100277

Capacity

∠	∅	□	▭	kW
90°	120 mm	110 mm	90 x 140 mm	1.1 / 2.2
45°	105 mm	90 mm	90 x 100 mm	1.1 / 2.2

Technical specifications

Voltage	3 Phase / 380 Volt
Motor power	1.1 / 2.2 kW
Cutting speed	18 / 36 RPM
Coolant system	Yes
Mitre cutting L+R	45° 0° -45° -90°
Saw blade dimensions ∅	350 x 2.5 x 32 mm
Weight ca.	245 kg
Article number	667100094

Options



MPS roller conveyors

- 2000 series, closed model
- Width 350 mm, roller pitch 250 mm
- Height 900 mm ± 50 mm
- Color RAL7001 and RAL7011



MPS measuring systems

Manual or automatic movable length stop systems. Available from 2 meters. Suitable for mounting on MPS roller conveyors.

Wisent VC315

Stationary vertical circular saw machine

- Sturdy one piece steel machine base with chip tray and cooling lubrication system
- 3 Phase motor, 400 Volt, 1.3-1.8 kW
- 2 cutting speeds 33 / 66 rpm
- Adjustable vertical dovetail guide on column
- Hardened and grounded gears
- Oil bath lubrication
- Mitre cutting left + right 45° - 0 - 60°
- Hydro-pneumatic adjustable saw feed
- HSS circular saw blade Ø315 mm, shaft hole 32 mm
- Automatic opening safety cover
- Flat rotating round saw table
- Quick vice with anti-burr clamp
- Changeable wear plates on clamping jaws
- Saw bed height ca. 900 mm
- Integrated coolant system, large capacity coolant pump
- Central control panel with zero voltage safety switch and emergency stop
- Weight ca. 270 kg

Machine comes complete with:

- HSS circular saw blade Ø315 mm, shaft hole 32 mm
- Base cabinet
- Coolant system
- Anti-burr clamp

All Wisent sawing machines can be fitted with MPS roller conveyors and MPS measuring systems



Capacity				
∠	∅	□	▭	kW
90°	100 mm	90 mm	75 x 135 mm	1.3 / 1.8
45° L+R	100 mm	90 mm	75 x 100 mm	1.3 / 1.8
60°	80 mm	70 mm	70 x 80 mm	1.3 / 1.8

Technical specifications	
Voltage	3 Phase / 400 Volt
Motor power	1.3 / 1.8 kW
Cutting speed	2 speeds 33 / 66 m/min
Vice opening	160 mm
Coolant system	Standard
Mitre cutting L+R	45 – 0 – 60°
Saw blade dimensions ∅	315 x 2.5 x 32 mm
Weight ca.	270 kg
Article number	438103145

Wisent saw blades VC315		
Dimensions mm	TPI	Article number
Saw blade ∅ 315 x 2.5 x 32 mm	120T	127100220
Saw blade ∅ 315 x 2.5 x 32 mm	160T	127100214
Saw blade ∅ 315 x 2.5 x 32 mm	180T	127100211
Saw blade ∅ 315 x 2.5 x 32 mm	200T	127100208
Saw blade ∅ 315 x 2.5 x 32 mm	220T	127100205
Saw blade ∅ 315 x 2.5 x 32 mm	240T	127100202

Wisent VC315 HA Stationary vertical circular saw machine

- Sturdy one piece steel machine base with chip tray and cooling lubrication system
- 3 Phase motor, 400 Volt, 1.3-1.8 kW
- 2 cutting speeds 33 / 66 rpm
- Adjustable vertical dovetail guide on column
- Hardened and grounded gears
- Oil bath lubrication
- Mitre cutting left + right 45° - 0 - 60°
- Hydro-pneumatic adjustable saw feed
- HSS circularsaw blade Ø315 mm, shaft hole 32 mm
- Automatic opening safety cover
- Flat rotating round saw table
- Quick vice with anti-burr clamp
- Changeable wear plates on clamping jaws
- Saw bed height ca. 900 mm
- Integrated coolant system, large capacity coolant pump
- Central control panel with zero voltage safety switch and emergency stop
- Weight ca. 300 kg

Machine comes complete with:

- HSS circular saw blade Ø315 mm, shaft hole 32 mm
- Base cabinet
- Coolant system
- Anti-burr clamp

All Wisent sawing machines can be fitted with MPS roller conveyors and MPS measuring systems



Capacity				
∠	∅	□	▭	kW
90°	100 mm	90 mm	80 x 135 mm	1.3 / 1.8
45° L+R	100 mm	90 mm	80 x 100 mm	1.3 / 1.8
60°	80 mm	70 mm	70 x 70 mm	1.3 / 1.8

Technical specifications	
Voltage	3 Phase / 400 Volt
Motor power	1.3 / 1.8 kW
Cutting speed	2 speeds 33 / 66 m/min
Vice opening	160 mm
Coolant system	Standard
Mitre cutting L+R	45 – 0 – 60°
Saw blade dimensions ∅	315 x 2.5 x 32 mm
Weight ca.	300 kg
Article number	438103151

Wisent saw blades VC315 HA		
Dimensions mm	TPI	Article number
Saw blade ∅ 315 x 2.5 x 32 mm	120T	127100220
Saw blade ∅ 315 x 2.5 x 32 mm	160T	127100214
Saw blade ∅ 315 x 2.5 x 32 mm	180T	127100211
Saw blade ∅ 315 x 2.5 x 32 mm	200T	127100208
Saw blade ∅ 315 x 2.5 x 32 mm	220T	127100205
Saw blade ∅ 315 x 2.5 x 32 mm	240T	127100202

Wisent AC350 Aluminium mitre circular saw machine

- Sturdy one piece steel base cabinet with door
- 3 Phase motor, 400 Volt, 1.5 kW with brake
- 1 Cutting speed 3.300 RPM
- Toothed belt saw blade drive motor
- Mitre cutting left + right 45° - 0 - 45°
- Mitre freely adjustable, 9 fixed locking positions
- 45° -30° -22.5° -15° - 0° -15° -22.5° -30° and 45°
- False mitre (tilt) freely adjustable 0° - 45°L
- Manual saw feed
- HM (TCT) circular saw blade Ø350 mm, shaft hole 30 mm
- Automatic opening safety cover
- Flat rotating round saw table
- 2 adjustable horizontal pneumatic material clamps
- Changeable wear plates on clamping jaws
- Saw bed height ca. 885 mm
- Chip extraction nozzle at rear of sawing machine
- Venturi water-based spray lubrication
- Compressed air connection on machine
- Weight ca. 110 kg

Machine comes complete with:

- HM (TCT) circular saw blade Ø350 mm, shaft hole 30 mm
- Base cabinet
- Horizontal pneumatic material clamps

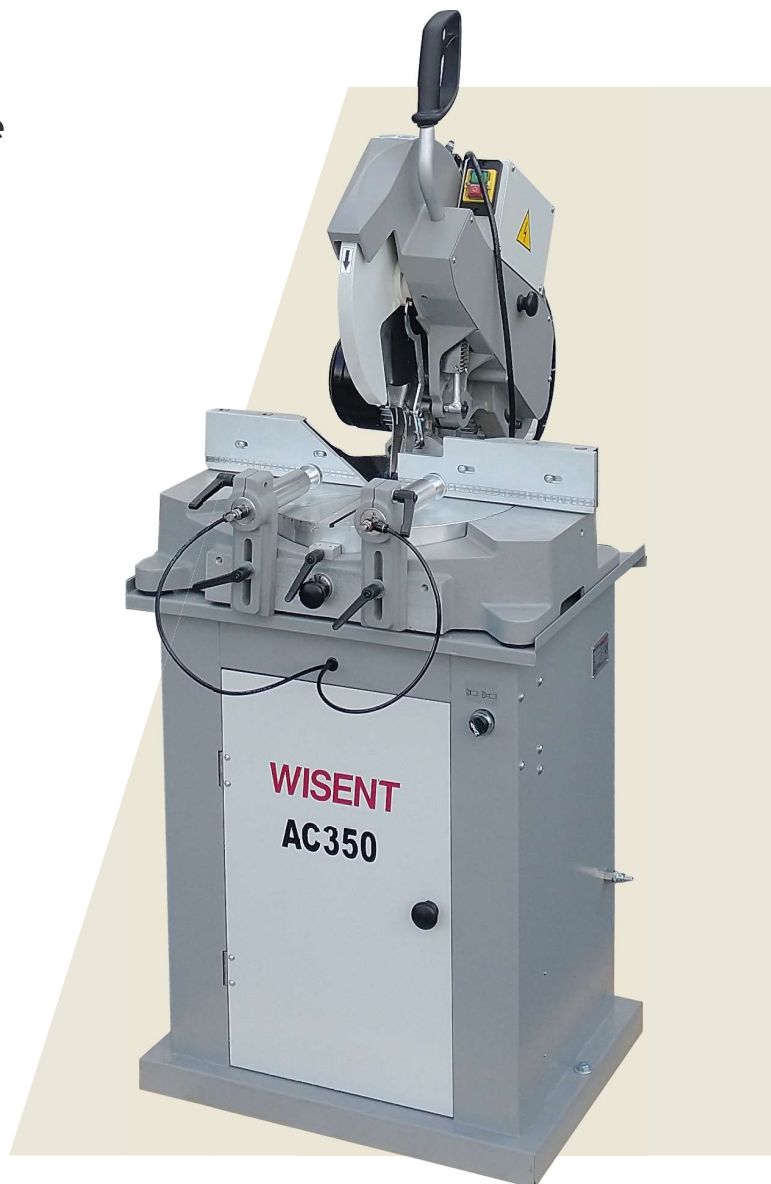

Wisent saw blades AC350

Dimensions mm	TPI	Article number
Saw blade Ø 350 x 3.2 x 30 mm	84T	647350084
Saw blade Ø 350 x 3.2 x 30 mm	108T	647350108

Capacity

∠	∅	□	▭	kW
90°	100 mm	100 mm	195 x 100 mm	1.5
45° L+R	100 mm	100 mm	135 x 100 mm	1.5

Technical specifications

Voltage	3 Phase / 400 Volt
Motor power	1.5 kW
Cutting speed	3.300 RPM
Vice opening	200 mm
Coolant system	Standard
Mitre cutting L+R	45° - 0 - 45°
Saw blade dimensions ∅	350 mm
Weight ca.	110 kg
Article number	667100250

Options



Wisent extraction system

- Type VA1C
- 400 Volt, 2.2 kW
- Extraction volume 2.800 m³/h
- Complete with hose set



MPS extensions

2000 series closed roller conveyors and manually or automatically movable length stop systems. Available from 2 meters. Suitable for mounting on MPS roller conveyors..

Wisent AC400PB Aluminium mitre circular saw machine

- Sturdy one piece steel machine base
- 3 Phase motor, 400 Volt, 1.3 kW with brake
- 1 Cutting speed 2.800 RPM
- Toothed belt saw blade drive motor
- Horizontal turntable with swivel range 75° - 0° - 75°
- Mitre freely adjustable, 3 fixed locking positions 45° - 0° -45°
- Hydro-pneumatic adjustable saw feed
- Lubrication system type MSD115 mounted at rear of sawing machine
- Backstay adjustable about 70 mm backward for greater cutting capacity
- Two-hand control start sawing on frontside
- HM (TCT) circular saw blade Ø400 mm, shaft hole 30 mm
- Large hinged drill guard with safety switch
- Flat rotating round saw table
- 2 adjustable vertical pneumatic material clamps
- Adjustable rear guide with changeable wear plates on clamping jaws
- Saw bed height ca. 885 mm
- Chip extractor at rear of sawing machine
- Removable chip tray at rear of sawing machine
- Compressed air connection on machine including air nozzle
- Weight ca. 120 kg

Machine comes complete with:

- HM (TCT) circular saw blade Ø400 mm, shaft hole 30 mm
- Base cabinet
- vertical pneumatic material clamps



Wisent saw blades AC400PB

Dimensions mm	TPI	Article number
Saw blade Ø 400 x 4.0 x 30 mm	108T	647400108
Saw blade Ø 400 x 4.0 x 30 mm	120T	647400120

Capacity

∠	∅	□	▭	kW
90°	110 mm	100 mm	140 x 60 mm	1.3
45° L+R	100 mm	100 mm	100 x 60 mm	1.3

Technical specifications

Voltage	3 Phase / 400 Volt
Motor power	1.3 kW
Cutting speed	2.800 RPM
Vice opening	None
Microdosing system	Standard
Mitre cutting L+R	75 - 0 - 75°
Afm. saw blade Ø mm.	400 mm
Weight ca.	120 kg
Article number	667100255

Options



Wisent extraction system

- Type VA1C
- 400 Volt, 2.2 kW
- Extraction volume 2.800 m³/h
- Complete with hose set



MPS extensions

2000 series closed roller conveyors and manually or automatically movable length stop systems. Available from 2 meters. Suitable for mounting on MPS roller conveyors..

Wisent JIH16 CE Aluminium mitre circular saw machine

- Sturdy one piece steel machine base
- 3 Phase motor, 400 Volt, 2.25 kW
- 1 Cutting speed 3.600 RPM
- Toothed belt saw blade drive motor
- Grinded on bearings rotating horizontal saw table
- Mitre freely adjustable 45° - 0° -45°
- Hydro-pneumatic adjustable saw feed
- Two-hand control start sawing on frontside
- HM (TCT) circular saw blade Ø400 mm, shaft hole 30 mm
- Large hinged drill guard with safety switch
- 2 adjustable horizontal pneumatic material clamps
- Vertical clamping by adjustable cap clamp
- Adjustable rear guide with changeable wear plates on clamping jaws
- Backstay adjustable about 60 mm backward for greater cutting capacity
- Saw bed height ca. 850 mm
- Chip extractor at rear of sawing machine
- Lubrication system mounted at front of sawing machine
- Compressed air connection on machine including air nozzle
- Weight ca. 400 kg

Machine comes complete with:

- HM (TCT) circular saw blade Ø400 mm, shaft hole 30 mm
- Base cabinet
- Horizontal pneumatic material clamps



Wisent saw blades JIH16

Dimensions mm	TPI	Article number
Saw blade Ø 405 x 3.2 x 30 mm	120T	3752000016

Capacity

∠	∅	□	▭	kW
90°	110 mm	100 mm	200 x 50 mm	2.25
45° L+R	110 mm	90 mm	150 x 50 mm	2.25

Technical specifications

Voltage	3 Phase / 400 Volt
Motor power	2.25 kW
Cutting speed	3.600 RPM
Vice opening	None
Coolant system	Standard
Mitre cutting L+R	45 - 0 - 45°
Saw blade dimensions ∅	400 mm
Weight ca.	400 kg
Article number	375100016

Options



Wisent extraction system

- Type VA1C
- 400 Volt, 2.2 kW
- Extraction volume 2.800 m³/h
- Complete with hose set



MPS extensions

2000 series closed roller conveyors and manually or automatically movable length stop systems. Available from 2 meters. Suitable for mounting on MPS roller conveyors..

DRILLING MACHINES



Wisent magnetic drilling machines

Manual portable magnetic drilling machines

Wisent core drills (also called magnetic or cutter drills) are designed to drill large holes in steel with a relatively small drilling machine. What used to require a column drill, there is now a Wisent core drill. Due to its portability, the machine can be taken to the material to be drilled rather than bringing the heavy material to a fixed column drilling machine.



Wisent SMD30

- 100 mm extra in height adjustable drill unit



Wisent SMD35

- 60 mm extra in height adjustable drill unit

Wisent magnetic drilling machines

Type	Voltage	Electric motor Watt	Drill Capacity	Magnet holding power (2 pcs)	Speed RPM	Coolant system	Machine Weight	Article number
SMD 30	1 Phase / 230 Volt	1050 Watt	Ø 30 mm	750 kgf	750	Standard	11 kg	602000030
SMD 35	1 Phase / 230 Volt	1050 Watt	Ø 35 mm	750 kgf	550 / 750	Standard	14 kg	602000035

Specifications

- 1 Phase motor 230 Volt 1.050 Watt
- Hardened steel gears in a compact grease filled magnesium aluminium gear housing
- Compact, lightweight, strong and the finely balance
- Electrical wiring mounted inside
- Shaft Weldon 19mm
- Equipped with integrated coolant system
- Cooling/lubrication from the inside (long life core drills)
- Feed handle can be mounted on both sides of the machine
- Adjustable dovetail guide
- Extra height adjustable for drilling with spiral drills
- Supplied complete in plastic carrying case

Wisent cutters

Tungsten Carbide quality cutters with Micro Grade cutting surface



Cutters equipped with Weldon 19mm and “One-touch” insert, fit into the most common machines. Suitable for drilling in standard steel, alloy steel and difficult to cut materials.



Features

- High quality
- Long tool life
- Sharpenable
- Good chip removal
- Smooth finish
- Specially designed cutting surface
- Attractively priced
- Perfect result



Wisent Cutters		
Type	Length	Ø mm
HSS 330L	30 mm	12 - 70
HSS 55L	55 mm	12 - 70
HM 35L	35 mm	12 - 52
HM 50L	50 mm	12 - 150
HM 75L	75 mm	16 - 70

Wisent Cutters					
	HSS30L	HSS55L	HM35L	HM50L	HM75L
Drill depth	30 mm	55 mm	35 mm	50 mm	75 mm

Diameter	HSS30L	HSS55L	HM35L	HM50L	HM75L
12 mm	602130120	602155120	602235120	602250120	
13 mm	602130130	602155130	602235130	602250130	
14 mm	602130140	602155140	602235140	602250140	
15 mm	602130150	602155150	602235150	602250150	
16 mm	602130160	602155160	602235160	602250160	602275160
17 mm	602130170	602155170	602235170	602250170	602275170
18 mm	602130180	602155180	602235180	602250180	602275180
19 mm	602130190	602155190	602235190	602250190	602275190
20 mm	602130200	602155200	602235200	602250200	602275200
21 mm	602130210	602155210	602235210	602250210	602275210
22 mm	602130220	602155220	602235220	602250220	602275220
23 mm	602130230	602155230	602235230	602250230	602275230
24 mm	602130240	602155240	602235240	602250240	602275240
25 mm	602130250	602155250	602235250	602250250	602275250
26 mm	602130260	602155260	602235260	602250260	602275260
27 mm	602130270	602155270	602235270	602250270	602275270
28 mm	602130280	602155280	602235280	602250280	602275280
29 mm	602130290	602155290	602235290	602250290	602275290
30 mm	602130300	602155300	602235300	602250300	602275300
31 mm	602130310	602155310	602235310	602250310	602275310

Wisent Cutters

Diameter	HSS30L	HSS55L	HM35L	HM50L	HM75L
32 mm	602130320	602155320	602235320	602250320	602275320
33 mm	602130330	602155330	602235330	602250330	602275330
34 mm	602130340	602155340	602235340	602250340	602275340
35 mm	602130350	602155350	602235350	602250350	602275350
36 mm	602130360	602155360	602235360	602250360	602275360
37 mm	602130370	602155370	602235370	602250370	602275370
38 mm	602130380	602155380	602235380	602250380	602275380
39 mm	602130390	602155390	602235390	602250390	602275390
40 mm	602130400	602155400	602235400	602250400	602275400
41 mm	602130410	602155410	602235410	602250410	602275410
42 mm	602130420	602155420	602235420	602250420	602275420
43 mm	602130430	602155430	602235430	602250430	602275430
44 mm	602130440	602155440	602235440	602250440	602275440
45 mm	602130450	602155450	602234450	602250450	602275450
46 mm	602130460	602155460	602234460	602250460	602275460
47 mm	602130470	602155470	602234470	602250470	602275470
48 mm	602130480	602155480	602234480	602250480	602275480
49 mm	602130490	602155490	602234490	602250490	602275490
50 mm	602130500	602155500	602234500	602250500	602275500
51 mm	602130510	602155510	602235510	602250510	602275510
52 mm	602130520	602155520	602235520	602250520	602275520
53 mm	602130530	602155530		602250530	602275530
54 mm	602130540	602155540		602250540	602275540
55 mm	602130550	602155550		602250550	602275550
56 mm	602130560	602155560		602250560	602275560
57 mm	602130570	602155570		602250570	602275570
58 mm	602130580	602155580		602250580	602275580
59 mm	602130590	602155590		602250590	602275590
60 mm	602130600	602155600		602250600	602275600
61 mm	602130610	602155610		602250610	602275610
62 mm	602130620	602155620		602250620	602275620
63 mm	602130630	602155630		602250630	602275630
64 mm	602130640	602155640		602250640	602275640
65 mm	602130650	602155650		602250650	602275650
66 mm	602130660	602155660		602250660	602275660
67 mm	602130670	602155670		602250670	602275670
68 mm	602130680	602155680		602250680	602275680
69 mm	602130690	602155690		602250690	602275690
70 mm	602130700	602155700		602250700	602275700

Wisent cutters HM50L larger diameters

Diameter	HM50L	Diameter	HM50L	Diameter	HM50L
71 mm	602250710	98 mm	602250980	125 mm	602251250
72 mm	602250720	99 mm	602250990	126 mm	602251260
73 mm	602250730	100 mm	602251000	127 mm	602251270
74 mm	602250740	101 mm	602251010	128 mm	602251280
75 mm	602250750	102 mm	602251020	129 mm	602251290
76 mm	602250760	103 mm	602251030	130 mm	602251300
77 mm	602250770	104 mm	602251040	131 mm	602251310
78 mm	602250780	105 mm	602251050	132 mm	602251320
79 mm	602250790	106 mm	602251060	133 mm	602251330
80 mm	602250800	107 mm	602251070	134 mm	602251340
81 mm	602250810	108 mm	602251080	135 mm	602251350
82 mm	602250820	109 mm	602251090	136 mm	602251360
83 mm	602250830	110 mm	602251100	137 mm	602251370
84 mm	602250840	111 mm	602251110	138 mm	602251380
85 mm	602250850	112 mm	602251120	139 mm	602251390
86 mm	602250860	113 mm	602251130	140 mm	602251400
87 mm	602250870	114 mm	602251140	141 mm	602251410
88 mm	602250880	115 mm	602251150	142 mm	602251420
89 mm	602250890	116 mm	602251160	143 mm	602251430
90 mm	602250900	117 mm	602251170	144 mm	602251440
91 mm	602250910	118 mm	602251180	145 mm	602251450
92 mm	602250920	119 mm	602251190	146 mm	602251460
93 mm	602250930	120 mm	602251200	147 mm	602251470
94 mm	602250940	121 mm	602251210	148 mm	602251480
95 mm	602250950	122 mm	602251220	149 mm	602251490
96 mm	602250960	123 mm	602251230	150 mm	602251500
97 mm	602250970	124 mm	602251240		



Wisent tabletop drill / tapping machines

Versatile line of professional v-belt, tooth belt and gear driven tabletop drills. Indispensable in e.g. the machine shop, construction workshop, technical service or the classroom. For drilling different diameters in various types of steels, ferrous and nonferrous. Choice of the standard tabletop drilling machines, for general drilling work, or the Wisent machine equipped with variable speed and tapping function. Wisent stands for quality. The machines are very reliable and solid and low in maintenance. All Wisent machines meet the latest CE guidelines with emergency stop on the front of the drill and the correct drill spindle shielding and pulleycover security. Safety comes first.

V-belt drive

The Wisent D1612 and D2312 are equipped with v-belt drive. To set the desired speed, the v-belt must be placed in a different position on the pulley. The motor plate is unlocked through the left screw button and moved forward with the right lever. This creates space to place the v-belt at a different position on the pulley. Tighten the right lever and lock the left screw knob again and the correct speed is set.

Tooth belt drive

The Wisent D23VT and D23VTC are equipped with a variable speed and tooth belt drive with two pulley positions. One position for high speed of smaller drill diameters and one position for low speed of larger drill diameters. The desired speed is easily set by turning the speed controller on the front of the control panel. To drill larger diameters, the toothed belt can be moved to the second position on the pulley. The motor plate is unlocked through the left screw knob and right lever pushed forward. This creates space to move the toothed belt to the other position on the pulley. Tighten right lever and lock left screw knob again and the correct speed range is set. Wisent D23VT and D23VTC are also equipped with an automatic tapping function.



Wisent **D1612**



Wisent **D2312**



Wisent **D23VT**



Wisent **D23VTC**

Wisent Tabletop drill / tapping machines

Type	D1612	D2312	D23VT	D23VTC
Voltage	3 Phase / 400 Volt	3 Phase / 400 Volt	3 Phase / 400 Volt	3 Phase / 400 Volt
Motor power	0.375 kW	0.75 kW	0.75 kW	0.75 kW
Drive type	V-belt	V-belt	Tooth belt	Tooth belt
Drill capacity	Ø 16 mm	Ø 23 mm	Ø 23 mm	Ø 23 mm
Tap capacity	-	-	M10	M10
Spindle cone MT	MT2	MT2	MT2	MT2
Dist. spindle - column	180 mm	180 mm	180 mm	180 mm
Column	Ø 80 mm	Ø 80 mm	Ø 80 mm	Ø 80 mm
Number of speeds	12	12	2 - Variable	2 - Variable
RPM min./max.	300 – 2.360	300 – 2.360	150 – 3.000	150 – 3.000
Weight ca.	74 kg	78 kg	98 kg	160 kg
Article number	253500004	253500010	253500011	253500111

Wisent D1612

V-belt driven tabletop drill

- Drill capacity Ø16 mm
- Spindle cone MT2
- 3 Phase motor, 400 Volt, 375 Watt
- 10 drilling speeds 300 – 2.360 RPM
- Manual drill feed
- Adjustable drill depth stop
- Drill depth 80 mm
- Distance spindle - column 180 mm
- Distance spindle - table 0 ~ 510 mm
- Distance spindle - base 660 mm
- LED machine light
- Extra strong column Ø80 mm
- Flattened, square, tilting and rotating drill table
- Dimensions drilling table 280 x 280 mm
- T-slot 12 mm
- Dimensions base 505 x 305 mm
- Low maintenance
- Safe: Electromagnetic motor protection switch
Drill guard with microswitch
Front mounted emergency stop
- Excluding drilling tools
- Weight ca. 74 kg



Also available in 230 volt

Article number: 253500001

Accessories

	<p>Wisent key chucks</p> <p>KDC 1613 - B16 / 1 - 13 mm KDC 1616 - B16 / 3 - 16 mm</p>
	<p>Wisent drill chuck arbors</p> <p>Drill chuck arbors for inserting a chuck into a tapered connection.</p> <p>MC 2 - B16</p>
	<p>Wisent machine clamps</p> <p>Machine clamps for clamping the material. Various versions available.</p>
	<p>Wisent drill guards</p> <p>Suitable for all Wisent table and column drills and several other brands. Security function with micro switch. 180° rotatable, and adjustable in height.</p>

Technical specifications

Voltage	3 Phase / 400 Volt
Motor power	0.375 kW
Drill capacity	Ø 16 mm
Tap capacity	-
Spindle cone MT	MT2
Distance spindle-column	180 mm
Column	Ø 80 mm
Number of speeds	12
RPM min./max.	300 – 2.360
Weight ca.	74 kg
Article number	253500004

Wisent D2312

V-belt driven tabletop drill

- Drill capacity Ø23 mm
- Spindle cone MT2
- 3 Phase motor, 400 Volt, 750 Watt
- 10 drilling speeds 300 – 2.360 RPM
- Manual drill feed
- Adjustable drill depth stop
- Drill depth 80 mm
- Distance spindle - column 180 mm
- Distance spindle - table 0 ~ 510 mm
- Distance spindle - base 660 mm
- LED machine light
- Extra strong column Ø80 mm
- Flattened, square, tilting and rotating drill table
- Dimensions drilling table 280 x 280 mm
- T-slot 12 mm
- Dimensions base 505 x 305 mm
- Low maintenance
- Safe: Electromagnetic motor protection switch
Drill guard with microswitch
Front mounted emergency stop
- Excluding drilling tools
- Weight ca. 78 kg



Also available in 230 volt

Article number: 253500007

Accessories

	<p>Wisent key chucks</p> <p>KDC 1613 - B16 / 1 - 13 mm KDC 1616 - B16 / 3 - 16 mm</p>
	<p>Wisent drill chuck arbors</p> <p>Drill chuck arbors for inserting a chuck into a tapered connection.</p> <p>MC 2 - B16</p>
	<p>Wisent machine clamps</p> <p>Machine clamps for clamping the material. Various versions available.</p>
	<p>Wisent drill guards</p> <p>Suitable for all Wisent table and column drills and several other brands. Security function with micro switch. 180° rotatable, and adjustable in height.</p>

Technical specifications

Voltage	3 Phase / 400 Volt
Motor power	0.75 kW
Drill capacity	Ø 23 mm
Tap capacity	-
Spindle cone MT	MT2
Distance spindle-column	180 mm
Column	Ø 80 mm
Number of speeds	12
RPM min./max.	300 – 2.360
Weight ca.	78 kg
Article number	253500010

Wisent D23VT

Tooth belt driven tabletop drill press

- Drill capacity Ø23 mm
- Tap capacity M12
- Spindle cone MT2
- 3 Phase motor, 400 Volt, 750 Watt
- Variable speed, 2 sp. 150 ~ 3.000 RPM
- Manual drill feed
- RPM digitally readable
- Adjustable drill depth stop
- Drill depth 90 mm
- Distance spindle - column 180 mm
- Distance spindle - table 0 ~ 510 mm
- Distance spindle - base 660 mm
- LED machine light
- Extra strong column Ø80 mm
- Flattened, square, tilting and rotating drill table
- Dimensions drilling table 280 x 280 mm
- T-slot 12 mm
- Dimensions base 505 x 305 mm
- Low maintenance
- Safe: Electromagnetic motor protection switch
Drill guard with microswitch
Front mounted emergency stop
- Excluding drilling tools
- Weight ca. 120 kg



Also available in 230 volt

Article number: 253500012

Accessories

	<p>Wisent key chucks</p> <p>KDC 1613 - B16 / 1 - 13 mm KDC 1616 - B16 / 3 - 16 mm</p>
	<p>Wisent drill chuck arbors</p> <p>Drill chuck arbors for inserting a chuck into a tapered connection.</p> <p>MC 2 - B16</p>
	<p>Wisent machine clamps</p> <p>Machine clamps for clamping the material. Various versions available.</p>
	<p>Wisent drill guards</p> <p>Suitable for all Wisent table and column drills and several other brands. Security function with micro switch. 180° rotatable, and adjustable in height.</p>

Technical specifications

Voltage	3 Phase / 400 Volt
Motor power	0.75 kW
Drill capacity	Ø 23 mm
Tap capacity	M10
Spindle cone MT	MT2
Distance spindle-column	180 mm
Column	Ø 80 mm
Number of speeds	2 - Variable
RPM min./max.	150 - 3.000
Weight ca.	98 kg
Article number	253500011

Wisent D23VTC

Tooth belt driven tabletop drill press

- Includes base cabinet with tool drawer
- Height adjustable drill head
- Drill capacity Ø23 mm
- Tap capacity M12
- Spindle cone MT2
- 3 Phase motor, 400 Volt, 750 Watt
- Variable speed, 2 sp. 150 ~ 3.000 RPM
- Manual drill feed
- RPM digitally readable
- Adjustable drill depth stop
- Drill depth 90 mm
- Distance spindle - column 180 mm
- Distance spindle - table 200 ~ 770 mm
- LED machine light
- Extra strong column Ø80 mm
- Dimensions drilling table 300 x 320 mm
- 3st. T-slot 12 mm
- Dimensions base cabinet 480 x 390 mm
- Low maintenance
- Safe: Electromagnetic motor protection switch
Drill guard with microswitch
Front mounted emergency stop
- Excluding drilling tools
- Weight ca. 120 kg



Also available in 230 volt
Article number: 253500112

Accessories

	<p>Wisent key chucks</p> <p>KDC 1613 - B16 / 1 - 13 mm KDC 1616 - B16 / 3 - 16 mm</p>
	<p>Wisent drill chuck arbors</p> <p>Drill chuck arbors for inserting a chuck into a tapered connection.</p> <p>MC 2 - B16</p>
	<p>Wisent machine clamps</p> <p>Machine clamps for clamping the material. Various versions available.</p>
	<p>Wisent drill guards</p> <p>Suitable for all Wisent table and column drills and several other brands. Security function with micro switch. 180° rotatable, and adjustable in height.</p>

Technical specifications

Voltage	3 Phase / 400 Volt
Motor power	0.75 kW
Drill capacity	Ø 23 mm
Tap capacity	M12
Spindle cone MT	MT2
Distance spindle-column	180 mm
Column	Ø 80 mm
Number of speeds	2 - Variable
RPM min./max.	150 – 3.000
Weight ca.	160 kg
Article number	253500111

Wisent DG25

Gear driven tabletop drill

- Drill capacity Ø25 mm
- Spindle cone MT3
- 3 Phase motor, 400 Volt, 0.7/0.9 kW
- 8 drilling speeds 105 / 210 / 350 / 445 / 700 / 890 / 1.490 / 2.900 RPM
- Drill head of machine 360° rotatable and adjustable in height
- Manual drill feed
- Adjustable drill depth stop
- Drill depth 125 mm
- Distance spindle - column 255 mm
- Distance spindle - base 160 ~ 520 mm
- Extra strong column Ø110 mm
- Flattened rectangular drilling table/base
- Dimensions drilling table/base 340 x 560 mm
- T-slot 14 mm
- Low maintenance
- Safe: Electromagnetic motor protection switch
Drill guard with microswitch
Front mounted emergency stop
- Excluding drilling tools
- Height 1.080 mm
- Weight ca. 145 kg



Accessories

	<p>Wisent key chucks</p> <p>KDC 1613 - B16 / 1 - 13 mm KDC 1616 - B16 / 3 - 16 mm</p>
	<p>Wisent drill chuck arbors</p> <p>Drill chuck arbors for inserting a chuck into a tapered connection.</p> <p>MC 3 - B16</p>
	<p>Wisent machine clamps</p> <p>Machine clamps for clamping the material. Various versions available.</p>
	<p>Wisent drill guards</p> <p>Suitable for all Wisent table and column drills and several other brands. Security function with micro switch. 180° rotatable, and adjustable in height.</p>

Technical specifications

Voltage	3 Phase / 400 Volt
Motor power	0.7 / 0.9 kW
Drill capacity	Ø 25 mm
Tap capacity	-
Spindle cone MT	MT3
Distance spindle-column	255 mm
Column	Ø 110 mm
Number of speeds	8
RPM min./max.	105 – 2.900
Weight ca.	145 kg
Article number	667100034

Wisent Column drill / tapping machines

Versatile line of professional v-belt, tooth belt and gear driven tabletop drills. Indispensable in e.g. the machine shop, construction workshop, technical service or the classroom. For drilling different diameters in various types of steels, ferrous and nonferrous. Choice of the standard tabletop drilling machines, for general drilling work, or the Wisent machine equipped with variable speed and tapping function. Wisent stands for quality. The machines are very reliable and solid and low in maintenance. All Wisent machines meet the latest CE guidelines with emergency stop on the front of the drill and the correct drill spindle shielding and pulleycover security. Safety comes first.

V-belt drive

The Wisent DC2509 and D3218P are equipped with v-belt drive. To set the desired speed, the v-belt must be placed in a different position on the pulley. The motor plate is unlocked through the left screw button and moved forward with the right lever. This creates space to place the v-belt at a different position on the pulley. Tighten the right lever and lock the left screw knob again and the correct speed is set.

Tooth belt drive

The Wisent DC32VP, DT32VA and DT40VA are equipped with a variable speed and tooth belt drive with two pulley positions. One position for high speed of smaller drill diameters and one position for low speed of larger drill diameters. The desired speed is easily set by turning the speed controller on the front of the control panel. To drill larger diameters, the toothed belt can be moved to the second position on the pulley. The motor plate is unlocked through the left screw knob and right lever pushed forward. This creates space to move the toothed belt to the other position on the pulley. Tighten right lever and lock left screw knob again and the correct speed range is set. Wisent DT32VA and DT40VA are also equipped with an automatic tapping function.



**Wisent
DC2509**



**Wisent
DC3218P**



**Wisent
DC32VP**



**Wisent
DT32VA**



**Wisent
DT40VA**

	V-belt driven		Tooth belt driven		
Type	DC2509	DC3218P	DC32VP	DT32VA	DT40VA
Voltage	3 Phase / 400 Volt	3 Phase / 400 Volt	3 Phase / 400 Volt	3 Phase / 400 Volt	3 Phase / 400 Volt
Motor power	0.75 kW	1.125 kW	1.125 kW	1.5 kW	2.2 kW
Drive type	V-belt	V-belt	Tooth belt	Tooth belt	Tooth belt
Drill capacity	Ø 25 mm	Ø 32 mm	Ø 32 mm	Ø 32 mm	Ø 40 mm
Tap capacity	-	-	-	M16	M20
Spindle cone MT	MT3	MT3	MT3	MT3	MT4
Dist. spindle-column	225 mm	210 mm	210 mm	230 mm	300 mm
Column	Ø 92 mm	Ø 92 mm	Ø 92 mm	Ø 102 mm	Ø 115 mm
Number of speeds	9	18	2 - Variable	2- Variable	2- Variable
RPM min./max.	220 - 1.660	105 - 2.650	100 - 2.470	80 - 2.500	70 - 2.000
Weight ca.	143 kg	176 kg	176 kg	329 kg	330 kg
Article number	253500016	253500019	253500022	253500029	253500032

Wisent Column drill / tapping machines

Tooth belt drive with automatic feed

The Wisent DTA32VP and DTA40VP are equipped with a variable speed and tooth belt drive.

The desired speed can easily be set by turning the speed control on the front of the control panel. The motor of the Wisent DTA40VP has two speeds, position 1 and 2 so that in low and high speed the speed is variable adjustable. The Wisent DTA32VP and DTA40VP are also equipped with an automatic tap function and automatic drill feed.

Gear drive

The Wisent DG25, DCG25 and DTG35A are equipped with gear drive. The desired speed can be set by using one of the gear levers. The drills have a gearbox with steel and pertinax gears, making the transmission silent. In order to prevent damage to the pertinax gear, the speed must be set with the motor completely stopped. The motor has two speeds, position 1 and 2. Without the switch levers the high or low speed can be selected. The Wisent DTG35A is equipped with an automatic tap function and automatic drill feed.



**Wisent
DTA32VP**



**Wisent
DTA40VP**



**Wisent
DG25**



**Wisent
DCG25**



**Wisent
DTG35A**

Automatic feed

Gear driven / Automatic feed

DTA32VP	DTA40VP	Type	DG25	DCG25	DTG35A
3 Phase / 400 Volt	3 Phase / 400 Volt	Voltage	3 Phase / 400 Volt	3 Phase / 400 Volt	3 Phase / 400 Volt
1.5 kW	1.5 kW	Motor power	0.7 / 0.9 kW	0.7 / 0.9 kW	2.2 kW
Tooth belt	Tooth belt	Drive type	Gear	Gear	Gear
Ø 32 mm	Ø 40 mm	Drill capacity	Ø 25 mm	Ø 25 mm	Ø 35 mm
M16	M20	Tap capacity	-	-	M18
MT3	MT4	Spindle cone MT	MT3	MT3	MT4
240 mm	265 mm	Dist. spindle - column	255 mm	255 mm	325 mm
Ø 92 mm	Ø 115 mm	Column	Ø 110 mm	Ø 110 mm	Ø 125 mm
2- Variable	2 - Variable	Number of speeds	8	8	8 speeds
150 - 2.500	65 - 2.000	RPM min./max.	105 - 2.650	105 - 2.900	75 - 3.010
300 kg	400 kg	Weight ca.	145 kg	190 kg	290 kg
253500091	253500095	Article number	667100034	667100035	667100037

Wisent DC2509

V-belt driven column drill

- Drill capacity Ø25 mm
- Spindle cone MT3
- 3 Phase motor, 400 Volt, 750 Watt
- 9 drilling speeds 220 – 1.660 RPM
- Manual drill feed
- Adjustable drill depth stop
- Drill depth 125 mm
- Distance spindle - column 225 mm
- Distance spindle - table 0 ~ 720 mm
- Distance spindle - base 1.140 mm
- LED machine light
- Extra strong column Ø92 mm
- Flattened, square, tilting and rotating drill table
- Dimensions drilling table 350 x 350 mm
- T-slot 12 mm
- Dimensions base 580 x 330 mm
- Low maintenance
- Safe: Electromagnetic motor protection switch
Drill guard with microswitch
Front mounted emergency stop
- Excluding drilling tools
- Weight ca. 143 kg



Accessories

	<p>Wisent key chucks</p> <p>KDC 1613 - B16 / 1 - 13 mm KDC 1616 - B16 / 3 - 16 mm</p>
	<p>Wisent drill chuck arbors</p> <p>Drill chuck arbors for inserting a chuck into a tapered connection.</p> <p>MC 3 - B16</p>
	<p>Wisent machine clamps</p> <p>Machine clamps for clamping the material. Various versions available.</p>
	<p>Wisent drill guards</p> <p>Suitable for all Wisent table and column drills and several other brands. Security function with micro switch. 180° rotatable, and adjustable in height.</p>

Technical specifications

Voltage	3 Phase / 400 Volt
Motor power	0.75 kW
Drill capacity	Ø 25 mm
Tap capacity	-
Spindle cone MT	MT3
Distance spindle-column	225 mm
Column	Ø 92 mm
Number of speeds	9
RPM min./max.	220 – 1.660
Weight ca.	143 kg
Article number	253500016

Wisent DCG25

Gear driven column drill

- Drill capacity Ø25 mm
- Spindle cone MT3
- 3 Phase motor, 400 Volt, 0.7/0.9 kW
- 8 drilling speeds 105 / 210 / 350 / 445 / 700 / 890 / 1.490 / 2.900 RPM
- Drill head of machine 360° rotatable and adjustable in height
- Manual drill feed
- Adjustable drill depth stop
- Drill depth 125 mm
- Distance spindle - column 255 mm
- Distance spindle - table 0 ~ 740 mm
- Distance spindle - base 850 ~ 1.160 mm
- Extra strong column Ø110 mm
- Flattened rectangular swivel drilling table
- Dimensions drilling table 350 x 500 mm
- T-slot 14 mm
- Dimensions base 400 x 500 mm
- Low maintenance
- Safe: Electromagnetic motor protection switch
Drill guard with microswitch
Front mounted emergency stop
- Excluding drilling tools
- Height 1.750 mm
- Weight ca. 190 kg



Accessories

	<p>Wisent key chucks</p> <p>KDC 1613 - B16 / 1 - 13 mm KDC 1616 - B16 / 3 - 16 mm</p>
	<p>Wisent drill chuck arbors</p> <p>Drill chuck arbors for inserting a chuck into a tapered connection.</p> <p>MC 3 - B16</p>
	<p>Wisent machine clamps</p> <p>Machine clamps for clamping the material. Various versions available.</p>
	<p>Wisent drill guards</p> <p>Suitable for all Wisent table and column drills and several other brands. Security function with micro switch. 180° rotatable, and adjustable in height.</p>

Technical specifications

Voltage	3 Phase / 400 Volt
Motor power	0.7 / 0.9 kW
Drill capacity	Ø 25 mm
Tap capacity	-
Spindle cone MT	MT3
Distance spindle-column	255 mm
Column	Ø 110 mm
Number of speeds	8
RPM min./max.	105 – 2.900
Weight ca.	190 kg
Article number	667100035

Wisent DC3218P

V-belt driven column drill

- Drill capacity Ø32 mm
- Spindle cone MT3
- 3 Phase motor, 400 Volt, 1.125 Watt
- 18 drilling speeds 105 – 2.650 RPM
- Manual drill feed
- Adjustable drill depth stop
- Drill depth 110 mm
- Distance spindle - column 210 mm
- Distance spindle - table 0 ~ 810 mm
- Distance spindle - base 1.200 mm
- LED machine light
- Extra strong column Ø92 mm
- Integrated coolant system
- Flattened, square, tilting, and reversible drilling table with machine clamp
- Dimensions drilling table 270 x 360 mm
- T-slot 12 mm
- Dimensions base 560 x 420 mm
- Low maintenance
- Safe: Electromagnetic motor protection switch
Drill guard with microswitch
Front mounted emergency stop
- Excluding drilling tools
- Weight ca. 176 kg



Accessories

	<p>Wisent key chucks</p> <p>KDC 1613 - B16 / 1 - 13 mm KDC 1616 - B16 / 3 - 16 mm</p>
	<p>Wisent drill chuck arbors</p> <p>Drill chuck arbors for inserting a chuck into a tapered connection.</p> <p>MC 3 - B16</p>
	<p>Wisent machine clamps</p> <p>Machine clamps for clamping the material. Various versions available.</p>
	<p>Wisent drill guards</p> <p>Suitable for all Wisent table and column drills and several other brands. Security function with micro switch. 180° rotatable, and adjustable in height.</p>

Technical specifications

Voltage	3 Phase / 400 Volt
Motor power	1.125 kW
Drill capacity	Ø 32 mm
Tap capacity	-
Spindle cone MT	MT3
Distance spindle-column	210 mm
Column	Ø 92 mm
Number of speeds	18
RPM min./max.	105 – 2.650
Weight ca.	176 kg
Article number	253500019

Wisent DC32VP

Tooth belt driven column drill

- Drill capacity Ø32 mm
- Spindle cone MT3
- 3 Phase motor, 400 Volt, 1.125 Watt
- Variable speed (2) 100 ~ 680 and 400 ~ 2.500 RPM
- Manual drill feed
- Adjustable drill depth stop
- Drill depth 110 mm
- Distance spindle - column 210 mm
- Distance spindle - table 0 ~ 810 mm
- Distance spindle - base 1.200 mm
- LED machine light
- Extra strong column Ø92 mm
- Integrated coolant system
- Flattened, square, tilting, and reversible drilling table with machine clamp
- Dimensions drilling table 270 x 360 mm
- T-slot 12 mm
- Dimensions base 560 x 420 mm
- Low maintenance
- Safe: Electromagnetic motor protection switch
Drill guard with microswitch
Front mounted emergency stop
- Excluding drilling tools
- Weight ca. 176 kg



Accessories

	<p>Wisent key chucks</p> <p>KDC 1613 - B16 / 1 - 13 mm KDC 1616 - B16 / 3 - 16 mm</p>
	<p>Wisent drill chuck arbors</p> <p>Drill chuck arbors for inserting a chuck into a tapered connection.</p> <p>MC 3 - B16</p>
	<p>Wisent machine clamps</p> <p>Machine clamps for clamping the material. Various versions available.</p>
	<p>Wisent drill guards</p> <p>Suitable for all Wisent table and column drills and several other brands. Security function with micro switch. 180° rotatable, and adjustable in height.</p>

Technical specifications

Voltage	3 Phase / 400 Volt
Motor power	1.125 kW
Drill capacity	Ø 32 mm
Tap capacity	-
Spindle cone MT	MT3
Distance spindle-column	210 mm
Column	Ø 92 mm
Number of speeds	2 - Variable
RPM min./max.	100 - 2.500
Weight ca.	176 kg
Article number	253500022





Wisent DT32VA

Tooth belt driven column drill

- Drill capacity Ø32 mm
- Tap capacity M16
- Spindle cone MT3
- 3 Phase motor, 400 Volt, 1.5 kW
- Variable speed (2) 80 ~ 1.000 and 230 ~ 2.500 RPM
- RPM digitally readable
- Manual drill feed
- Adjustable drill depth stop
- Drill depth 140 mm
- Distance spindle - column 230 mm
- Distance spindle - table 0 ~ 720 mm
- Distance spindle - base 1.130 mm
- LED machine light
- Extra strong column Ø102 mm
- Integrated coolant system
- Flattened, square, tilting, and reversible drilling table with machine clamp
- Dimensions drilling table 320 x 480 mm
- T-slot 14 mm
- Dimensions base 660 x 465 x 140 mm
- Low maintenance
- Safe: Electromagnetic motor protection switch
Drill guard with microswitch
Front mounted emergency stop
- Excluding drilling tools
- Weight ca. 290 kg



Accessories

	<p>Wisent key chucks</p> <p>KDC 1613 - B16 / 1 - 13 mm KDC 1616 - B16 / 3 - 16 mm</p>
	<p>Wisent drill chuck arbors</p> <p>Drill chuck arbors for inserting a chuck into a tapered connection.</p> <p>MC 3 - B16</p>
	<p>Wisent machine clamps</p> <p>Machine clamps for clamping the material. Various versions available.</p>
	<p>Wisent drill guards</p> <p>Suitable for all Wisent table and column drills and several other brands. Security function with micro switch. 180° rotatable, and adjustable in height.</p>

Technical specifications

Voltage	3 Phase / 400 Volt
Motor power	1.5 kW
Drill capacity	Ø 32 mm
Tap capacity	M16
Spindle cone MT	MT3
Distance spindle-column	230 mm
Column	Ø 102 mm
Number of speeds	2 - Variable
RPM min./max.	80 - 2.500
Weight ca.	290 kg
Article number	253500029

Wisent DTG35A

Gear driven column drill press with automatic feed

- Drill capacity Ø35 mm
- Tap capacity M18
- Spindle cone MT4
- 3 Phase motor, 400 Volt, 1.5/1.8 kW
- Left- and right turning
- 8 drilling speeds 75 / 160 / 265 / 440 / 535 / 890 / 1.490 / 3.010 RPM
- Drill head of machine 360° rotatable and adjustable in height
- Automatic drill feed (4) 0.1 – 0.15 – 0.22 – 0.33 mm/omw.
- Automatic electromagnetic feed
- Adjustable drill depth stop
- Drill depth 150 mm
- Distance spindle - column 325 mm
- Distance spindle - table 0 ~ 740 mm
- Distance spindle - base 850 ~ 1.100 mm
- Extra strong column Ø125 mm
- Flattened rectangular swivel drilling table
- Dimensions drilling table 400 x 500 mm
- T-slot 14 mm
- Dimensions base 400 x 670 mm
- Low maintenance
- Safe: Electromagnetic motor protection switch
Drill guard with microswitch
Front mounted emergency stop
- Excluding drilling tools
- Height 1.830 mm



Accessories

	<p>Wisent key chucks</p> <p>KDC 1613 - B16 / 1 - 13 mm KDC 1616 - B16 / 3 - 16 mm</p>
	<p>Wisent drill chuck arbors</p> <p>Drill chuck arbors for inserting a chuck into a tapered connection.</p> <p>MC 4 - B16</p>
	<p>Wisent machine clamps</p> <p>Machine clamps for clamping the material. Various versions available.</p>
	<p>Wisent drill guards</p> <p>Suitable for all Wisent table and column drills and several other brands. Security function with micro switch. 180° rotatable, and adjustable in height.</p>

Technical specifications

Voltage	3 Phase / 400 Volt
Motor power	1.5 / 1.8 kW
Drill capacity	Ø 35 mm
Tap capacity	M18
Spindle cone MT	MT4
Distance spindle-column	325 mm
Column	Ø 125 mm
Number of speeds	8
RPM min./max.	75 – 3.010
Weight ca.	290 kg
Article number	667100037

Wisent DT40VA

Tooth belt driven column drill press

- Drill capacity Ø40 mm
- Tap capacity M20
- Spindle cone MT4
- 3 Phase motor, 400 Volt, 2.2 kW
- Variable speed (2) 70 ~ 750 and 195 ~ 2.000 RPM
- RPM digitally readable
- Manual drill feed
- Adjustable drill depth stop
- Drill depth 145 mm
- Distance spindle - column 300 mm
- Distance spindle - table 0 ~ 715 mm
- Distance spindle - base 1.145 mm
- LED machine light
- Extra strong column Ø115 mm
- Integrated coolant system
- Flattened, square drilling table
- Dimensions drilling table 400 x 470 mm
- T-slot 14 mm
- Dimensions base 660 x 465 x 140 mm
- Low maintenance
- Safe: Electromagnetic motor protection switch
Drill guard with microswitch
Front mounted emergency stop
- Excluding drilling tools
- Weight ca. 330 kg



Accessories

	<p>Wisent key chucks</p> <p>KDC 1613 - B16 / 1 - 13 mm KDC 1616 - B16 / 3 - 16 mm</p>
	<p>Wisent drill chuck arbors</p> <p>Drill chuck arbors for inserting a chuck into a tapered connection.</p> <p>MC 3 - B16</p>
	<p>Wisent machine clamps</p> <p>Machine clamps for clamping the material. Various versions available.</p>
	<p>Wisent drill guards</p> <p>Suitable for all Wisent table and column drills and several other brands. Security function with micro switch. 180° rotatable, and adjustable in height.</p>

Technical specifications

Voltage	3 Phase / 400 Volt
Motor power	2.2 kW
Drill capacity	Ø 40 mm
Tap capacity	M20
Spindle cone MT	MT4
Distance spindle-column	300 mm
Column	Ø 115 mm
Number of speeds	2 - Variable
RPM min./max.	70 – 2.000
Weight ca.	330 kg
Article number	253500032

Wisent DTA32VP

Tooth belt driven column drill press with automatic feed

- Drill capacity Ø32 mm
- Tap capacity M16
- Spindle cone MT3
- 3 Phase motor, 400 Volt, 1.5 kW
- Variable speed 150 ~ 2.500 RPM
- RPM digitally readable
- Automatic drill feed (3) 0.05 – 0.1 – 0.2 mm/omw.
- Adjustable drill depth stop
- Drill depth 150 mm
- Distance spindle - column 240 mm
- Distance spindle - table 0 ~ 735 mm
- Distance spindle - base 1.150 mm
- LED machine light
- Extra strong column Ø92 mm
- Integrated coolant system
- Flattened, square drilling table
- Dimensions drilling table 400 x 500 mm
- T-slot 14 mm
- Dimensions base 590 x 395 mm
- Low maintenance
- Safe: Electromagnetic motor protection switch
Drill guard with microswitch
Front mounted emergency stop
- Excluding drilling tools
- Weight ca. 300 kg



Accessories

	<p>Wisent key chucks</p> <p>KDC 1613 - B16 / 1 - 13 mm KDC 1616 - B16 / 3 - 16 mm</p>
	<p>Wisent drill chuck arbors</p> <p>Drill chuck arbors for inserting a chuck into a tapered connection.</p> <p>MC 3 - B16</p>
	<p>Wisent machine clamps</p> <p>Machine clamps for clamping the material. Various versions available.</p>
	<p>Wisent drill guards</p> <p>Suitable for all Wisent table and column drills and several other brands. Security function with micro switch. 180° rotatable, and adjustable in height.</p>

Technical specifications

Voltage	3 Phase / 400 Volt
Motor power	1.5 kW
Drill capacity	Ø 32 mm
Tap capacity	M16
Spindle cone MT	MT3
Distance spindle-column	240 mm
Column	Ø 92 mm
Number of speeds	Variable
RPM min./max.	150 – 2.500
Weight ca.	300 kg
Article number	253500091

Wisent DTA40VP

Tooth belt driven column drill press with automatic feed

- Drill capacity Ø40 mm
- Tap capacity M20
- Spindle cone MT4
- 3 Phase motor, 400 Volt, 1.5 kW
- Variable speed (2) 65 ~ 540 and 245 ~ 2.000 RPM
- RPM digitally readable
- Automatic drill feed (3) 0.05 – 0.1 – 0.2 mm/omw.
- Adjustable drill depth stop
- Drill depth 150 mm
- Distance spindle - column 265 mm
- Distance spindle - table 250 ~ 650 mm
- Distance spindle - base 1.150 mm
- LED machine light
- Extra strong column Ø115 mm
- Integrated coolant system
- Flattened, square drilling table
- Dimensions drilling table 560 x 470 mm
- T-slot 14 mm
- Dimensions base 690 x 490 mm
- Low maintenance
- Safe: Electromagnetic motor protection switch
Drill guard with microswitch
Front mounted emergency stop
- Excluding drilling tools
- Weight ca. 400 kg



Accessories

	<p>Wisent key chucks</p> <p>KDC 1613 - B16 / 1 - 13 mm KDC 1616 - B16 / 3 - 16 mm</p>
	<p>Wisent drill chuck arbors</p> <p>Drill chuck arbors for inserting a chuck into a tapered connection.</p> <p>MC 4 - B16</p>
	<p>Wisent machine clamps</p> <p>Machine clamps for clamping the material. Various versions available.</p>
	<p>Wisent drill guards</p> <p>Suitable for all Wisent table and column drills and several other brands. Security function with micro switch. 180° rotatable, and adjustable in height.</p>

Technical specifications

Voltage	3 Phase / 400 Volt
Motor power	1.5 kW
Drill capacity	Ø 40 mm
Tap capacity	M20
Spindle cone MT	MT4
Distance spindle-column	265 mm
Column	Ø 115 mm
Number of speeds	2 - Variable
RPM min./max.	65 – 2.000
Weight ca.	400 kg
Article number	253500095

Drill Guards

Type M1	Type M2	Type L1	Type L2
			
microswitch	microswitch	microswitch	microswitch
Drill guard 180° rotatable and adjustable in height	Drill guard 180° rotatable and adjustable in height	Drill guard 180° rotatable and adjustable in height	Drill guard 180° rotatable and adjustable in height
	Protective glass height adjustable		Protective glass height adjustable
Height 200 mm	Height 120 ~ 200 mm	Height 200 mm	Height 120 ~ 200 mm
Width 230 mm	Width 230 mm	Width 270 mm	Width 270 mm

Machine clamps

Type	Easy Move		
Jaw width	120 mm		
Vice opening	100 mm		
Weight	20 kg		
Article number	667200146		
			
Type	MK 100	MK 125	
Jaw width	105 mm	125 mm	
Vice opening	100 mm	125 mm	
Weight	5 kg	12 kg	
Article number	667200100	667200110	
			
Type	MK4D	MK5D	MK6D
Jaw width	100 mm	130 mm	150 mm
Vice opening	100 mm	130 mm	150 mm
Weight	14 kg	28 kg	39 kg
Article number	667200120	667200122	667200124
			
Type	ZMK100	ZMK140	ZMK200
Jaw width	100 mm	140 mm	200 mm
Vice opening	100 mm	140 mm	200 mm
Weight	9 kg	18 kg	34 kg
Article number	667200130	667200132	667200134
			
Type	ZMK100S	ZMK140S	ZMK200S
Jaw width	100 mm	140 mm	200 mm
Vice opening	100 mm	140 mm	200 mm
Weight	7 kg	13 kg	26 kg
Article number	667200140	667200142	667200144
			

PIPEWORKING MACHINES



Wisent BSM75

Belt grinding machine

- Sturdy industrial belt grinding machine
- 3 Phase motor, 400 Volt, 3 kW
- Belt dimension 75 x 2.000 mm
- Large grinding surface 75 x 530 mm
- Flat grinding area fitted with graphite strip
- Belt speed 34 m/sec
- Dimension contact wheel 75 x 200 mm
- Fine-adjustment sanding belt
- Adjustable grinding support
- Spark box for collection of grinding residues
- Heavy stable base
- Quick adjustable workheight 580 ~ 1.100 mm
- Prepared for dust extraction
- Equipped with 400 volt socket outlet 5-pole 16 A
- Thermal overload protection
- Quick-change system for quick and easy changing of sanding belt
- Clearly laid out operating panel with zero voltage safety switch and emergency stop
- Weight ca. 85 kg

Machine comes complete with:

- Wisent sanding belt
- Eye protection glass

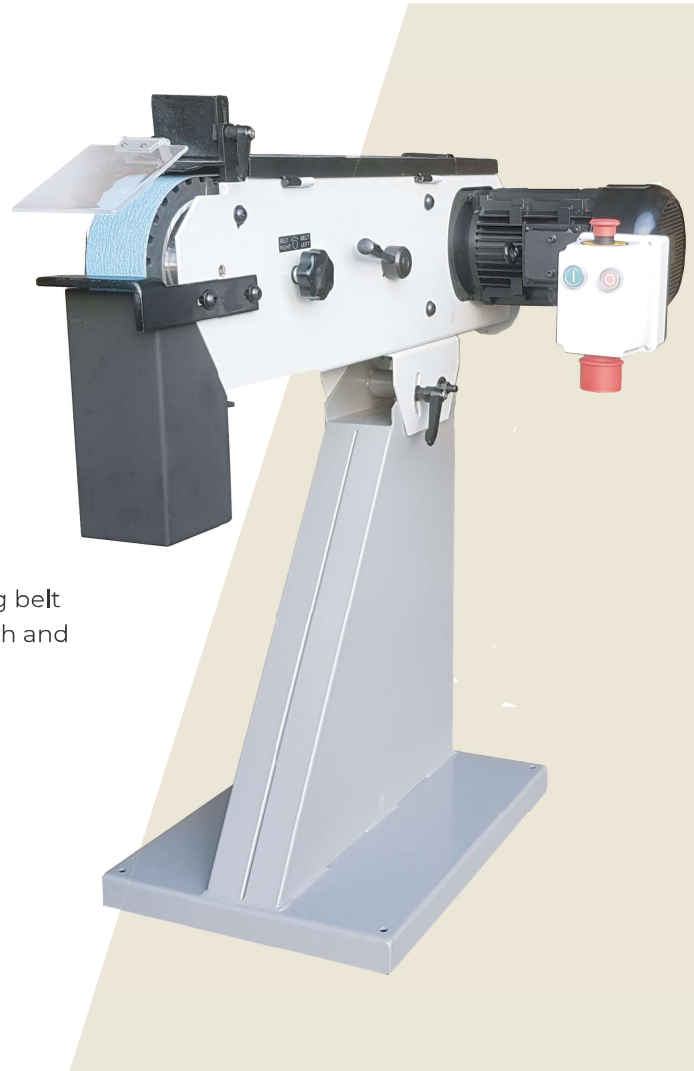

Technical specifications

Voltage	3 Phase / 400 Volt
Motor power	3.0 kW
Belt speed	34 m/sec
Dimension sanding belt	75 x 2.000 mm
Dimension grinding surface	75 x 530 mm
Dimension contact wheel	75 x 200 mm
Dimension drive wheel	75 x 220 mm
Workheight min./max.	580 ~ 1.100 mm
Weight ca.	85 kg
Article number	667100001

Accessories / Options



Wisent extraction system

Dust extraction, for mounting on rear of belt grinder
Item No. 667100004



Wisent sanding belt

- Dimensions 75 x 2.000 mm
- Brown version for standard use
- Blue version for aluminum and stainless steel
- Available in various grit types

Wisent BSMA75

Belt grinding machine with dust extraction

- Sturdy industrial belt grinding machine
- Integrated separately powered dust extraction
- Double extraction with filter in collection tray
- 3 Phase motor, 400 Volt, 4 kW
- Belt dimension 75 x 2.000 mm
- Large grinding surface 75 x 530 mm
- Flat grinding area fitted with graphite strip
- Belt speed 34 m/sec
- Dimension contact wheel 75 x 200 mm
- Quick-change system for quick and easy changing of sanding belt
- Fine-adjustment sanding belt
- Adjustable grinding support
- Spark box with dust extraction connection
- Base cabinet with integrated dust extraction
- Quick adjustable workheight 760 ~ 1.100 mm
- Prepared for dust extraction
- Clearly laid out operating panel with zero voltage safety switch and emergency stop
- Equipped with 400 volt socket outlet 5-pole 16 A
- Thermal overload protection
- Weight ca. 110 kg

Machine comes complete with:

- Wisent sanding belt
- Eye protection glass



Technical specifications

Voltage	3 Phase / 400 Volt
Motor power	4.0 kW
Belt speed	34 m/sec
Dimension sanding belt	75 x 2.000 mm
Dimension grinding surface	75 x 530 mm
Dimension contact wheel	75 x 200 mm
Dimension drive wheel	75 x 220 mm
Workheight min./max.	475 ~ 1.240 mm
Weight ca.	110 kg
Article number	667100003

Accessories / Options



Wisent sanding belt

- Dimensions 75 x 2.000 mm
- Brown version for standard use
- Blue version for aluminum and stainless steel
- Available in various grit types

Wisent BSM150

Belt grinding machine

- Sturdy industrial belt grinding machine
- 3 Phase motor, 400 Volt, 2.2/2.8 kW
- Belt dimension 150 x 2.000 mm
- Large grinding surface 150 x 530 mm
- Flat grinding area fitted with graphite strip
- 2 speeds 18 – 36 m/sec
- Dimension contact wheel 150 x 250 mm
- Quick-change system for quick and easy changing of sanding belt
- Fine-adjustment sanding belt
- Adjustable grinding support
- Spark box for collection of grinding residues
- Heavy stable base
- Quick adjustable workheight, 3 positions 580 mm, 835mm and 1.100 mm
- Prepared for dust extraction
- Clearly laid out operating panel with zero voltage safety switch and emergency stop
- Equipped with 400 volt socket outlet 5-pole 16 A
- Thermal overload protection
- Weight ca. 115 kg

Machine comes complete with:

- Wisent sanding belt
- Eye protection glass



Technical specifications

Voltage	3 Phase / 400 Volt
Motor power	2.2 / 2.8 kW
Belt speed	18 / 36 m/sec
Dimension sanding belt	150 x 2.000 mm
Dimension grinding surface	150 x 530 mm
Dimension contact wheel	150 x 250 mm
Dimension drive wheel	150 x 250 mm
Workheight min./max.	580 ~ 1.100 mm
Weight ca.	115 kg
Article number	667100007

Accessories / Options



Wisent extraction system

Dust extraction, for mounting on rear of belt grinder
Item No. 667100004



Wisent sanding belt

- Dimensions 150 x 2.000 mm
- Brown version for standard use
- Blue version for aluminum and stainless steel
- Available in various grit types

Wisent BSMA150

Belt grinding machine with dust extraction

- Sturdy industrial belt grinding machine
- Integrated separately powered dust extraction
- Double extraction with filter in collection tray
- 3 Phase motor, 400 Volt, 4 kW
- Belt dimension 150 x 2.000 mm
- Large grinding surface 150 x 530 mm
- Flat grinding area fitted with graphite strip
- Belt speed 34 m/sec
- Dimension contact wheel 150 x 250 mm
- Quick-change system for quick and easy changing of sanding belt
- Fine-adjustment sanding belt
- Adjustable grinding support
- Spark box with dust extraction connection
- Base cabinet with integrated dust extraction
- Quick adjustable workheight, 3 positions 750 mm, 895 mm and 1.100 mm
- Prepared for dust extraction
- Clearly laid out operating panel with zero voltage safety switch and emergency stop
- Equipped with 400 volt socket outlet 5-pole 16 A
- Thermal overload protection
- Weight ca. 135 kg

Machine comes complete with:

- Wisent sanding belt
- Eye protection glass



Technical specifications

Voltage	3 Phase / 400 Volt
Motor power	4.0 kW
Belt speed	34 m/sec
Dimension sanding belt	150 x 2.000 mm
Dimension grinding surface	150 x 530 mm
Dimension contact wheel	150 x 250 mm
Dimension drive wheel	150 x 250 mm
Workheight min./max.	750 - 895 - 1.100 mm
Weight ca.	135 kg
Article number	667100009

Accessories / Options



Wisent sanding belt

- Dimensions 150 x 2.000 mm
- Brown version for standard use
- Blue version for aluminum and stainless steel
- Available in various grit types

Wisent CVB75

Compact vertical belt grinding machine

- Sturdy industrial belt grinding machine
- Small floor space due to vertical design
- 3 Phase motor, 400 Volt, 3 kW
- Belt dimension 75 x 2.000 mm
- Belt speed 26 m/sec
- Dimension contact wheel 75 x 102 mm
- Quick and easy change of sanding belt
- Fine-adjustment sanding belt
- Adjustable grinding support
- Stable base 330 x 410 mm
- Fixed workheight 970 mm
- Prepared for dust extraction
- Clearly laid out operating panel with zero voltage safety switch and emergency stop
- Equipped with 400 volt socket outlet 5-pole 16 A
- Thermal overload protection
- Weight ca. 48 kg

Machine comes complete with:

- Wisent sanding belt
- Eye protection glass



Technical specifications

Voltage	400 Volt
Motor power	3.0 kW
Belt speed	26 m/sec
Dimension sanding belt	75 x 2.000 mm
Workheight min./max.	970 mm
Weight ca.	48 kg
Article number	667100018

Accessories / Options



Wisent sanding belt

- Dimensions 75 x 2.000 mm
- Brown version for standard use
- Blue version for aluminum and stainless steel
- Available in various grit types

Wisent OM200T

Tabletop deburring machine

- Sturdy industrial deburring machine
- 3 Phase motor, 400 Volt, 0.75 kW
- Includes deburring brush Ø200 x 45 mm
- 2 speeds 1.400 / 2.800 RPM
- Material stop height adjustable
- Quick change of deburring brush
- Prepared for dust extraction, Ø50 mm connection
- Low noise level
- Low vibration
- Low maintenance
- Clearly laid out operating panel with zero voltage safety switch and emergency stop
- Weight ca. 28 kg

Machine comes complete with:

- Deburring brush
- Eye protection glass



Technical specifications

Voltage	3 Phase / 400 Volt
Motor power	0.75 kW
Speed RPM	1.400 / 2.800
Dimension deburring brush	Ø200 x 45 mm
Weight ca.	28 kg
Article number	667100127

Accessories / Options



Wisent deburring brush

- 200 x 45 mm
- Steel
- Stainless steel

Wisent OM250S

Deburring machine

- Sturdy industrial deburring machine
- 3 Phase motor, 400 Volt, 1.2 kW
- Includes deburring brush Ø250 x 60 mm
- 2 speeds 1.400 / 2.800 RPM
- Material stop height adjustable
- Quick change of deburring brush
- Prepared for dust extraction, Ø50 mm connection
- Low noise level
- Low vibration
- Low maintenance
- Clearly laid out operating panel with zero voltage safety switch and emergency stop
- Weight ca. 105 kg

Machine comes complete with:

- Deburring brush
- Eye protection glass



Technical specifications

Voltage	3 Phase / 400 Volt
Motor power	1.2 kW
Speed RPM	1.400 / 2.800
Dimension deburring brush	Ø250 x 60 mm
Weight ca.	105 kg
Article number	667100130

Accessories / Options



Wisent deburring brush

- 250 x 60 mm
- Steel
- Stainless steel

Wisent PRC76A

Pipe grinding machine

- Sturdy industrial pipe grinding machine
- 3 Phase motor, 400 Volt, 2.2/2.8 kW
- Belt dimension 100 x 2.000 mm
- Large grinding surface 150 x 420 mm
- Flat grinding area fitted with graphite strip
- 2 speeds 15 – 30 m/sec
- Grinding angle variable adjustable from 30° to 90°
- Includes set of rolls from ½" to 2½" Gas (Ø20 t/m Ø76 mm)
- Quick change of grinding rollers without tools
- Quick and easy change of sanding belt
- Fine-adjustment sanding belt
- Spark box for collection of grinding residue
- Stable machine base with holder for 8 rolls
- Fixed workheight ca. 900 mm
- Prepared for dust-extraction
- Clearly laid out operating panel with zero voltage safety switch and emergency stop
- Equipped with 400 volt socket outlet 5-pole 16 A
- Thermal overload protection
- Weight ca. 180 kg

Machine comes complete with:

- Wisent sanding belt
- Eye protection glass
- Roller set



Diameter roller set

Ø 20	1/2"
Ø 26	3/4"
Ø 32	1"
Ø 42	1.1/4"
Ø 48	1.1/2"
Ø 60	2"
>Ø 76	2.1/2"

Technical specifications

Voltage	3 Phase / 400 Volt
Motor power	2.2 / 2.8 kW
Belt speed	15 - 30 m/sec
Belt dimension	100 x 2.000 mm
Roller set	1/2" – 2.1/2"
Workheight	900 mm
Weight ca.	180 kg
Article number	667100010

Accessories / Options



Wisent sanding belt

- Dimensions 100 x 2.000 mm
- Brown version for standard use
- Blue version for aluminum and stainless steel
- Available in various grit types

BENDING TOOLS



Wisent pipe notchers

Wisent pipe notchers lend themselves perfectly to welding pipes and tubes together at a 90° angle. Multiple diameters can be bent per version. Suitable for thin-walled steel, stainless steel, aluminum and other pipes.

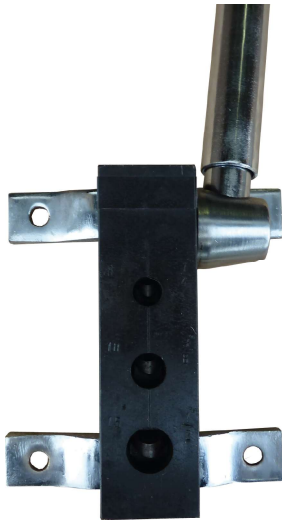

Wisent **WH 1422**



Wisent **WH 2843**



Wisent **WH 5061**

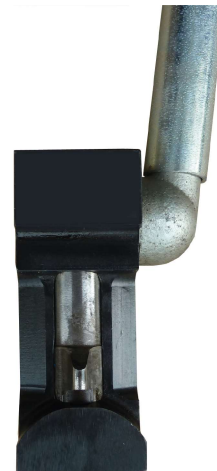

Wisent **WHZ**

Wisent Pipe notchers

Type	WH1422	WH2843	WH5061	WHZ
External pipe diameter	1/4' - 3/8' - 1/2'	3/4' - 1' - 1.1/4'	1.1/2' - 2'	3/4' - 2
Maximum wall thickness in ST40	3 mm	3 mm	3 mm	4 mm
Weight	6.5 kg	8.0 kg	15.0 kg	6.0 kg
Article number	667100040	667100042	667100044	667100046

Wisent BT40T

Horizontal bending table

- Sturdy industrial hydraulic bending table
- 3 Phase motor, 400 Volt, 1.5 kW
- Maximum operating pressure 40 tons
- Capacity strip 160 x 12 mm
- Comes complete with bending blocks (die and punch) 160 mm high
- Solid steel work table with underlying cylinder
- Dimensions work table 1.050 x 620 mm
- Free clear bending table
- Adjustable hydraulic working pressure with reading
- Quick tool change system
- Easily adjustable stroke length
- Manually operated material stop on right side of the machine
- Very precise adjustment of stroke, up to 250 mm
- Interference-free hydraulic unit
- PLC control with touchscreen and foot pedal
- Clearly laid out operating panel with zero-voltage switch and emergency stop
- Weight ca. 680 kg

Machine comes complete with:

- Comes complete with bending blocks (die and punch) 160 mm high



Technical specifications

Capacity	40 Ton
Capacity strip	160 x 12 mm
Motor power	1.5 kW
V Former	160 x 80 mm
Stroke length	250 mm
Table dimensions	1.050 x 620 mm
Weight ca.	680 kg
Article number	667100815

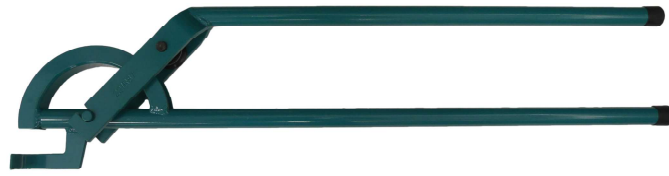

Pipe bender 90° with roller standard radius

Suitable for thin-walled heating pipe

Capacity Ø	10 mm	12 mm	15 mm	18 mm	20 mm	22 mm	28 mm
Bend radius Ø	43 mm	43 mm	60 mm	74 mm	87 mm	87 mm	95 mm
Length	460 mm	460 mm	600 mm	860 mm	900 mm	900 mm	1050 mm
Weight	1.40 kg	1.50 kg	2.30 kg	3.20 kg	4.30 kg	4.50 kg	5.70 kg
Article number	115200004	115200013	115200022	115200034	115200043	115200049	115200067*

*Executed with 2 rollers



Pipe bender 90° with slider standard radius

Suitable for copper pipe Suitable for copper pipe

Capacity Ø	10 mm	12 mm	15 mm	18 mm	20 mm	22 mm	28 mm
Bend radius Ø	43 mm	43 mm	60 mm	74 mm	87 mm	87 mm	95 mm
Length	460 mm	460 mm	600 mm	860 mm	900 mm	900 mm	1050 mm
Weight	1.40 kg	1.50 kg	2.30 kg	3.20 kg	4.30 kg	4.50 kg	5.70 kg
Article number	115200007*	115200010*	115200019*	115200031	11500040	115200046	115200064

*10 mm suitable for WICU pipe Ø 6 mm (10/6)

*12 mm suitable for WICU pipe Ø 8 mm (10/6)

*15 mm suitable for WICU pipe Ø 12 mm



Pipe bender 90° with slider

Suitable for WICU pipe *Size with casing / size WICU tube Suitable for thin-walled heating pipe

Capacity Ø	14 / 10	16 / 12	19 / 15	23 / 18	26 / 22	27 / 22
Bend radius Ø	60 mm	60 mm	75 mm	87 mm	95 mm	95 mm
Length	580 mm	600 mm	830 mm	830 mm	960 mm	980 mm
Weight	2.20 kg	2.20 kg	4.10 kg	6.90 kg	6.90 kg	6.90 kg
Article number	115200016	115200025	115200037	115200052	115200055*	115200058

*Suitable for imitation WICU



Pipe bender 90° with roller

Suitable for multilayer pipe, short construction length

Capacity Ø	14 mm	16 mm	18 mm	20 mm	25 mm	32 mm
Bend radius Ø	43 mm	43 mm	51 mm	62 mm	74 mm	108 mm
Length	300 mm	330 mm	450 mm	450 mm	470 mm	620 mm
Weight	1.40 kg	1.40 kg	1.70 kg	2.00 kg	2.00 kg	3.70 kg
Article number	115200103	115200106	115200109	115200112	115200115	115200118



Pipe bender 90° with roller short radius

Suitable for thin-walled heating pipe

Capacity Ø	12 mm	15 mm	22 mm
Bend radius Ø	30 mm	45 mm	75 mm
Length	440 mm	600 mm	900 mm
Weight	1.50 kg	2.20 kg	4.00 kg
Article number	115200079	115200088	115200097



Pipe bender 90° with slider short radius

Suitable for copper pipe

Capacity Ø	10 mm	12 mm	15 mm	22 mm
Bend radius Ø	30 mm	30 mm	45 mm	75 mm
Length	440 mm	440 mm	600 mm	900 mm
Weight	1.30 kg	1.60 kg	2.40 kg	4.10 kg
Article number	115200070	115200076	115200091	115200100



Pipe bender 90° with slider, extra short radius

Suitable for thin-walled heating pipe

Capacity Ø	15 mm	22 mm
Bend radius Ø	30 mm	52 mm
Length	600 mm	900 mm
Weight	2.20 kg	4.10 kg
Article number	115200085	115200094



Pipe bender 90° with roller

Suitable for copper and thin-walled heating pipe

Capacity Ø	10 mm
Bend radius Ø	30 mm
Length	240 mm
Weight	0.60 kg
Article number	115200001

WISENT